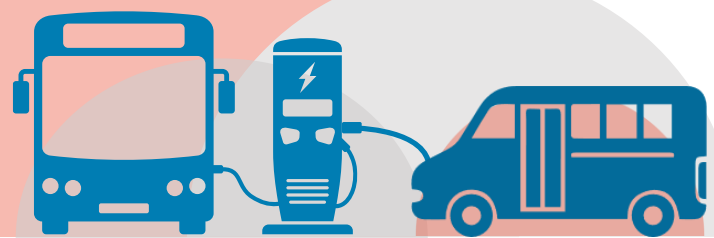




# ZERO EMISSION BUS FEASIBILITY STRATEGY & FLEET TRANSITION PLAN

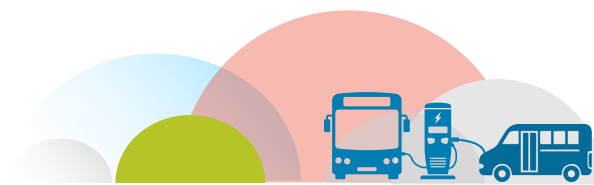
4/4/2024



## DISCLAIMER

In preparing this report, HDR relied, in whole or in part, on data and information provided by the Client and third parties that was current at the time of such usage, which information has not been independently verified by HDR and which HDR has assumed to be accurate, complete, reliable, and current. Therefore, while HDR has utilized its best efforts in preparing this report, HDR does not warrant or guarantee the conclusions set forth in this report which are dependent or based upon data, information or statements supplied by third parties or the client, or that the data and information have not changed since being provided in the report.

This report is intended for planning purposes for the Client, and for Client's sole and exclusive use and is not for the benefit of any third party and may not be distributed to, disclosed in any form to, used by, or relied upon by, any third party without prior written consent of HDR, which consent may be withheld in its sole discretion. Use of this preliminary feasibility report or any information contained herein, if by any party other than Client, shall be at the sole risk of such party and shall constitute a release and agreement by such party to defend and indemnify HDR and its affiliates, officers, employees and subcontractors from and against any liability for direct, indirect, incidental, consequential or special loss or damage or other liability of any nature arising from its use of the Report or reliance upon any of its content. To the maximum extent permitted by law, such release from and indemnification against liability shall apply in contract, tort (including negligence), strict liability, or any other theory of liability.

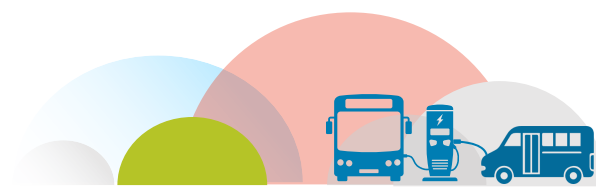


# CONTENTS

Executive Summary.....	i
<b>1 Introduction .....</b>	<b>1</b>
<b>2 Transit Fleet Zero Emission Transition Plan .....</b>	<b>2</b>
<b>3 System Level Planning.....</b>	<b>3</b>
3.1 Battery Electric Buses & Fueling Options.....	3
3.2 Energy Consumption Analysis.....	3
3.2.1 Methodology .....	3
3.2.2 Modelled Scenarios.....	5
3.2.3 Key Takeaways.....	6
<b>4 Operational Planning &amp; Deployment .....</b>	<b>8</b>
4.1 Fleet Deployment Plan .....	8
4.1.1 Fixed Route Transit Fleet .....	8
4.1.2 On-Demand/Specialized Transit Fleet.....	12
4.1.3 Software Systems.....	16
4.2 Facility & Infrastructure Plan.....	17
4.2.1 Milton Civic Operations Centre .....	17
4.2.2 Future Milton Transit Depot Facility.....	17
4.2.3 Vehicle Charging at Future Transit Facility.....	20
4.2.4 Future En-Route Charging Locations.....	20
<b>5 Capacity to Implement the Technology .....</b>	<b>22</b>
5.1 Staffing & Training Plan.....	22
5.1.1 Safe Workplace Policy and Standards .....	22
5.1.2 Training Program Development.....	24
5.1.3 Training Curriculum.....	25
5.1.4 Skills Assessment, Categorization, and Gap Identification.....	26
5.1.5 Training Program Implementation .....	27
5.1.6 Fleet Apprenticeship Program .....	27
5.1.7 Workforce Rightsizing.....	28
5.1.8 Funding Opportunities .....	29
<b>6 Financial Planning .....</b>	<b>30</b>
6.1 Fleet Transition Scenarios .....	30
6.2 Lifecycle Cost Analysis.....	30
6.2.1 Capital Cost Assumptions .....	31
6.2.2 Vehicle Capital Costs .....	32
6.2.3 Infrastructure Capital Costs .....	32
6.3 Operating & Maintenance Cost Assumptions.....	33
6.3.1 Operating Cost Assumptions .....	33
6.3.2 Fuel & Electricity Costs.....	35
6.3.3 Overall Lifecycle Cost Comparison .....	36
6.4 Funding Plan.....	37
<b>7 Environmental Benefits .....</b>	<b>38</b>



7.1	Assumptions & Methodology .....	38
7.2	GHG Emission Reduction Impacts .....	38
<b>8</b>	<b>Project Risks &amp; Mitigation.....</b>	<b>40</b>
	<b>Appendix A: Energy Modelling Analysis .....</b>	<b>44</b>
	<b>Appendix B: Facility Assessment .....</b>	<b>56</b>
	<b>Appendix C: Budget &amp; Financial Plan .....</b>	<b>75</b>
	<b>Appendix D: GHG Emissions Analysis .....</b>	<b>94</b>



## LIST OF FIGURES

Figure 1. Zero+ Inputs, Outputs, and Modelling Process.....	4
Figure 2. Fixed Route Transit Fleet Procurement Schedule (2023-2040) .....	11
Figure 3. Fixed Route Transit Fleet Composition by Purchase Year (2023-2040).....	11
Figure 4. 6M Specialized Fleet Composition by Purchase Year (2023-2034) .....	13
Figure 5. 6M Specialized Fleet Bus Procurement Schedule by Fuel Type (2023-2040).....	14
Figure 6. 8M Specialized Fleet Composition by Purchase Year (2023-2034) .....	15
Figure 7. 8M Specialized Fleet Bus Procurement Schedule by Fuel Type (2023-2040).....	16
Figure 8. Milton Transit Facility Conceptual Site Plan .....	19
Figure 9. Milton GO Station Aerial View .....	21
Figure 10. Annual GHG Emissions (CO <sub>2</sub> in Tonnes), BEB Scenario .....	39
Figure 11. Percentage GHG Reductions from Baseline in BEB Scenario.....	39
Figure 12. 525kWh BEB Depot Charging Only Model Outputs.....	45
Figure 13. 525kWh BEB Depot Charging Only - Weekday Service Block SOC Heatmap .....	46
Figure 14. 525kWh BEB Depot Charging Only Maximum Daily Power Profile at Depot Facility.....	47
Figure 15. Block Feasibility by Required Vehicle Battery Size .....	47
Figure 16. 675kWh BEB Depot Charging Only Model Outputs.....	48
Figure 17. 675kWh BEB Depot Charging Only - Weekday Service Block SOC Heatmap .....	48
Figure 18. 675kWh BEB Depot Charging Only Maximum Daily Power Profile at Depot Facility.....	49
Figure 19. BEB Depot and En-Route Charging Model .....	50
Figure 20. 525kWh BEB Depot and En-Route Charging - Weekday Service Block SOC Heatmap.....	51
Figure 21. Depot and En-Route Charging Maximum Daily Power Profile at Depot Facility .....	52
Figure 22. Equipment Required to Feed a Single Charging Module with 3 Plug-In Dispensers.....	57
Figure 23. Equipment Required to Feed a Single High-Speed Pantograph Charger.....	57
Figure 24. Wabtec Optimal Installation Position of Depot Pantograph .....	59
Figure 25. Example of Wall Mounted Cable Reel .....	60
Figure 26. Example of Alignment Markers for Proper Bus Positioning.....	61
Figure 27. Specialized Fleet Composition, Selected Years .....	89
Figure 28. Annual GHG Emissions, BEB Scenario, tonnes .....	95
Figure 29. Percentage GHG Reductions from Baseline in BEB Scenario.....	95



## LIST OF TABLES

Table 1. Capital Cost Comparison of 12-Metre Conventional Diesel Bus and Electric Bus (2023\$) .....	ii
Table 2. Annual Operating Cost Comparison of 12-Metre Conventional Diesel Bus and Electric Bus (2023\$) .....	iii
Table 3. Phased Fixed Route Fleet Deployment Plan .....	9
Table 4. Bus Procurement Schedule, Replacement and Expansion Breakdown (2023 - 2040) .....	9
Table 5. Expanded Service Feasibility Criteria .....	12
Table 6. Phased Specialized Fleet Composition by Phase .....	13
Table 7. 6M Specialized Fleet Procurement Schedule, Replacement and Expansion Breakdown (2023 - 2040) .....	14
Table 8. 8M Specialized Fleet Procurement Schedule, Replacement and Expansion Breakdown (2023 - 2040) .....	15
Table 9. Recommended Insulated Tools .....	24
Table 10. Recommended PPE for BEB Maintenance .....	24
Table 11. Capital Cost Comparison of 12M Conventional Diesel Bus and Electric Bus (2023\$) .....	30
Table 12. Annual Operating Cost Comparison of 12M Conventional Diesel Bus and Electric Bus (2023\$) .....	31
Table 13. Capital Unit Cost Assumptions, 2023\$ .....	32
Table 14. Infrastructure Phasing Assumptions .....	32
Table 15. Capital Cost Comparison, Millions of 2023\$, 2023-2050 .....	33
Table 16. Fixed Route Fleet O&M Unit Cost Assumptions, 2023\$ .....	34
Table 17. Specialized Fleet O&M Unit Cost Assumptions .....	34
Table 18. O&M Cost Comparison, Millions of 2023\$, 2023-2050 .....	35
Table 19. Fuel and Electricity Cost Assumptions, 2023\$ .....	35
Table 20. Fuel and Electricity Lifecycle Cost Comparison, Millions of 2023\$, 2023-2050 .....	36
Table 21. Overall Lifecycle Cost Comparison, Millions of 2023\$, 2023-2050 .....	36
Table 22. Total GHG Emissions (CO <sub>2</sub> in Tonnes) .....	38
Table 23. BEB Simulation Assumptions .....	44
Table 24. Summary of Feasible Blocks without Swap for 525 kWh BEB .....	46
Table 25. Summary of Feasible Blocks without Swap for 675 kWh BEB .....	49
Table 26. Specialized Fleet Modelling Inputs .....	53
Table 27. Baseline Scenario Model Results .....	54
Table 28. Expanded Fleet Scenario Analysis .....	54
Table 29. Mid-Day Recharging Scenario Analysis .....	55
Table 30. Dispenser Weight and Dimension Specifications of Select Manufacturers .....	60
Table 31. Curb Weight of BEBs from Select Manufacturers .....	67
Table 32. Capital Cost Assumptions, 2023\$ .....	76
Table 33. Infrastructure Unit Cost Assumptions, 2023\$ .....	76
Table 34. Unit Operating Cost, 2023\$ .....	77
Table 35. Annual Operating and Maintenance Cost Assumptions (2023\$) .....	78
Table 36. Diesel and Gasoline Unit Cost Assumptions, 2023\$ .....	78
Table 37. Electricity Unit Cost Assumptions, 2023\$ .....	79
Table 38. Maintenance Cost Unit Assumptions, 2023\$ .....	79
Table 39. On-Demand Fleet Operating and Maintenance Cost Assumptions, 2023\$ .....	80
Table 40. Baseline Scenario Annual Service Levels .....	80
Table 41. Baseline Scenario Periodic Capital Purchases Assumptions Based on the Fleet Retirement Schedule .....	81
Table 42. Annual Capital Cost Estimates, Selected years, 2023\$, Millions .....	81
Table 43. Baseline Scenario Periodic Operating Cost Estimates, 2023\$, Millions .....	81
Table 44. Baseline Scenario Periodic Maintenance Costs Estimates, 2023\$, Millions .....	82
Table 45. Baseline Scenario Periodic Diesel Costs, 2023\$, Millions .....	82

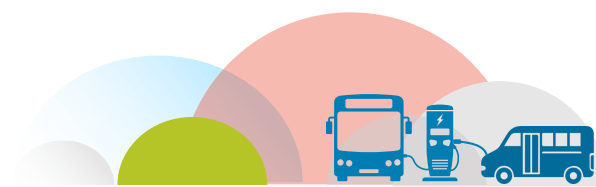


Table 46. Specialized Fleet Periodic Total Capital Purchases .....	82
Table 47. Baseline Scenario Specialized Transit Periodic Capital Cost Estimates, 2023\$, Millions .....	83
Table 48. Baseline Scenario Periodic Operations & Maintenance Costs, 2023\$, Millions .....	83
Table 49. Baseline Scenario Periodic Total Fuel Costs, 2023\$, Millions .....	83
Table 50. Baseline Scenario Summary, 2023\$, Millions, 2023-2050 .....	84
Table 51. BEB Transition Scenario Annual Service Levels .....	84
Table 52. BEB Scenario Periodic Capital Purchase Assumptions .....	85
Table 53. BEB Scenario Periodic Total Capital Cost Estimates, 2023\$, millions .....	86
Table 54. Infrastructure Phasing Assumptions, 2023\$ .....	86
Table 55. BEB Scenario Periodic Total Operating Cost Estimates, 2023\$, millions .....	87
Table 56. BEB Transition Scenario Fuel and Electricity Annual Usage .....	87
Table 57. BEB Scenario Periodic Total Fuel and Electricity Cost Estimates, 2023 \$, Millions .....	87
Table 58. BEB Scenario Periodic Total Operating Cost Estimates, 2023 \$, Millions .....	88
Table 59. BEB Scenario Periodic Specialized Transit Capital Purchases .....	88
Table 60. Specialized Transit Capital Costs, 2023\$ Millions .....	89
Table 61. BEB Scenario Periodic Specialized Fleet Maintenance Costs, 2023\$, Millions .....	89
Table 62. BEB Scenario Periodic Specialized Fleet Fuel Costs, 2023\$, Millions .....	90
Table 63. BEB Scenario Summary, 2023\$, Millions, 2023-2050 .....	90
Table 64. Capital Cost Comparison, 2023\$ Millions, 2023-2050 .....	91
Table 65. O&M Cost Comparison, 2023\$ Millions, 2023-2050 .....	92
Table 66. Fuel and Electricity Cost Comparison, 2023\$ Millions, 2023-2050 .....	92
Table 67. Overall Lifecycle Cost Comparison, Millions of 2023\$, 2023-2050 .....	93
Table 68. Total GHG Emissions (CO <sub>2</sub> in Tonnes), Baseline and BEB Scenarios .....	94

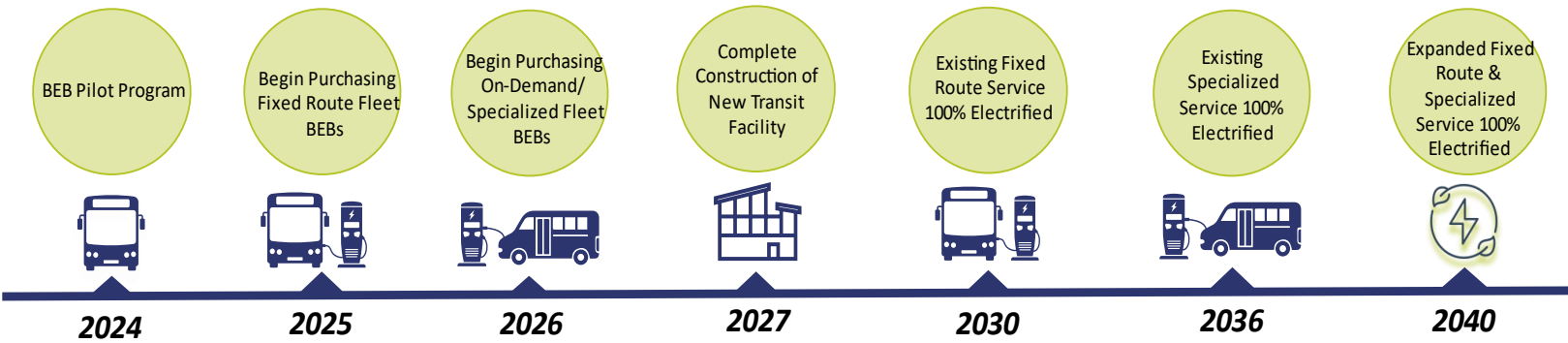


## EXECUTIVE SUMMARY

Transitioning to a zero emission fleet involves more than simply buying vehicles and a fueling system; the transition introduces new technology and processes into day-to-day operations. Successful fleet transition plans take a comprehensive approach to consider operational requirements, market conditions, available power, infrastructure demands, and costs. This Zero Emission Fleet Transition Plan incorporates all of these elements and is intended to serve as a roadmap for Milton Transit to convert their transit fleets to zero emission by 2040.

Overall, the development of a comprehensive electrification plan for transitioning Milton Transit’s fleet to electric vehicles was informed by several analyses conducted as part of this study. Key findings from these analyses performed during this study, including route modelling, schedule optimization, and the facilities assessment, are referred to in the step-by-step roadmap outlined in this Plan. Internal and external stakeholders were also engaged to understand the Town’s needs and collaboratively develop the Transition Plan with input from other departments. Important elements of the Plan include recommended bus specifications, charging systems, and software solutions tailored to Milton Transit’s operations, as well as maintenance and staff training considerations. The Transition Plan also includes timelines for fleet electrification, procurement coordination, service requirements, budgeting for capital and operating expenses, emission reduction projections, and an operational implementation plan addressing resource allocation and change management.

This study utilized energy modelling of battery electric buses (BEBs) using current route data to confirm operational feasibility and develop fleet charging strategies and recommendations for vehicle and charging infrastructure types. The comprehensive analysis summarized below provides Milton Transit with data to guide informed decisions involving capital programs and operations necessary to build key partnerships and support transition actions and phases.



As shown in the graphic above, this Transition Plan outlines a phased implementation approach that aligns with Milton Transit’s goal of 100% electrified service by 2040. This gradual integration allows Milton Transit to gain experience with BEB technology while the market evolves. BEBs are impacted by limited range and the time to recharge may not be consistent with current fleet operations, depending on the fleet’s operating profile. As technology advances, it’s anticipated that batteries will become bigger and lighter, increasing vehicle range and overall market availability of BEB profiles will become more diverse. Anticipated





advancements in battery and vehicle performance, as well as charging technology, will also enhance operational efficiency overtime.

The unit cost assumptions from the financial analysis are used to compare the operations of the baseline diesel bus fleet to the planned battery electric bus (BEB) fleet and provided in **Table 1** below. These costs reflect upfront capital costs for vehicles and electrical infrastructure, average annual cost of operations, maintenance, and diesel fuel and electricity costs. This table also includes the annual transfer to reserve needed to fund future vehicle and infrastructure replacements. All costs shown are in 2023 dollars and undiscounted. Overall, the capital costs of BEBs and related infrastructure are higher than diesel. However, maintenance cost and fuel cost savings associated with BEBs are significant relative to diesel.

**Table 1. Capital Cost Comparison of 12-Metre Conventional Diesel Bus and Electric Bus (2023\$)**

Cost Components	Baseline Scenario - Diesel	BEB Transition Scenario Battery-Electric	Variance (Per Bus Unit)
<b>Capital Expenditures</b>			
<b>Bus Acquisition – 12M</b>	\$915,024	\$1,909,686	\$994,662
<b>Mid Life Refurbishment</b>	\$120,000	\$7,000	-\$113,000
<b>Subtotal of Vehicle Costs</b>	<b>\$1,035,024</b>	<b>\$1,916,686</b>	<b>\$881,662</b>
<b>Charging Equipment*</b>			
<b>Plug-In Depot Charger Cabinet (150 kW)</b>	-	\$154,097	\$154,097
<b>Plug-In Depot Charger Wall-Mounted Dispenser</b>	-	\$25,265	\$25,265
<b>Plug-In Depot Charger Overhead Reel Dispenser</b>	-	\$32,158	\$32,158
<b>Subtotal of Charging Equipment Costs</b>	-	<b>\$211,520</b>	<b>\$211,520</b>
<b>Capital Expenditures Total</b>	<b>\$1,035,024</b>	<b>\$2,128,206</b>	<b>\$1,093,182**</b>

\*- Excludes major infrastructure and utility upgrades

\*\* - 106% increase in capital investment over baseline



**Table 2. Annual Operating Cost Comparison of 12-Metre Conventional Diesel Bus and Electric Bus (2023\$)**

Cost Components for Total Fleet	Diesel Bus	Battery-Electric Bus	Variance (Per Bus Unit)
<b>Operating Expenditures (per year)</b>			
Service Delivery and Administration, Training*	\$326,794	\$317,253	-\$9,541
Vehicle Maintenance + Fuel (Diesel, Gasoline, Carbon Levy)	\$99,843	\$49,620	-\$50,223
Electricity	-	\$26,502	\$26,502
Charger-Related Maintenance	-	\$5,959	\$5,959
<b>Subtotal of Service Delivery + Charging Equipment</b>	<b>\$426,637</b>	<b>\$399,334</b>	<b>-\$27,303</b>
<b>Contribution to Reserve for Asset Replacement</b>			
Vehicles (12-year life)	\$86,252	\$159,724	\$73,472
Charging Infrastructure (12-year life)	-	\$17,627	\$17,627
<b>Subtotal Contribution to Reserve for Asset Replacement</b>	<b>\$86,252</b>	<b>\$177,351</b>	<b>\$91,099</b>
<b>Total Annual Operating Cost (2023\$)</b>	<b>\$512,889</b>	<b>\$576,685</b>	<b>\$63,796</b>

\*-Based on average annual operating hours per vehicle, 2021 CUTA Statistics



# 1 INTRODUCTION

As one of the fastest-growing municipalities in Canada, the town of Milton (the Town) is well-positioned to lead its community toward a cleaner future by recognizing the importance of its energy consumption and emissions. The Town has seized its opportunities to plan for a healthy future and engage as a leader in this growing field by developing a vision reflective of its key goals. To achieve the Town of Milton's vision as a strong and prosperous community, especially in the areas of economy, society, and the environment, the Milton Green Innovation Plan<sup>1</sup> has been launched as the flagship program for the Town's commitment to responsible energy management and development. As part of this program, the Town has created a baseline review of energy usage and emissions and developed an action plan to ensure responsible resource management.

To further build on its commitment to sustainability, the Town brings forth recommended key actions and initiatives for Council approval through its Climate Change Work Plan on an annual basis, allowing for expanded efforts on environmental stewardship. These initiatives focus on integrating sustainability principles into both daily practices and long-term plans. Among these efforts are the Community and Corporate Energy Plan, Diesel-to-Electric Bus Conversion Pilot, Milton Transit Master Plan, and the Transportation Master Plan. Within the Climate Change Work Plan, it is noted that the Town has a goal to reduce greenhouse gas emissions (GHGs) by 20%. To achieve the goal, the work plan outlines specific approaches such as developing an electrification strategy for town vehicles, including transit. Additionally, the town of Milton is committed to reducing emissions in line with the Ontario Community Climate Action Plan (OCCAP).<sup>2</sup>

---

<sup>1</sup> [The Corporation of the Town of Milton Green Innovation Plan](#)

<sup>2</sup> [Ontario Community Climate Action Plan — March, 2023](#)



## 2 TRANSIT FLEET ZERO EMISSION TRANSITION PLAN

The transition from conventional gasoline and diesel buses to battery electric buses is a significant undertaking that requires robust planning, as it will impact many aspects of the organization. Infrastructure Canada has created the Zero Emission Transit Fund<sup>3</sup> (ZETF) to support organizations in transitioning their fleets. In addition to funding planning projects, it has a capital stream that provides opportunities for transit agencies to receive funding for capital projects. To apply for capital funding there are five specific planning elements that applicants must satisfy, and this Fleet Transition Plan has been developed to address those elements:

1. **System Level Planning:** Description of system-level planning undertaken for the project, such as analysis of zero emission bus (ZEB) technologies, energy consumption analysis, and identification of charging/refueling and facility requirements.
2. **Operational Planning & Deployment Strategy:** Outlines a fleet and infrastructure implementation plan that supports innovative and effective ZEB deployments and future operations. This strategy is informed by optimal route selection, service design, and procurement needs.
3. **Financial Planning:** Provides preliminary capital and operating cost estimates, including the anticipated lifecycle cost comparison encompassing fuel and maintenance costs.
4. **Capacity to Implement the Technology:** Assesses the organization’s current resources, skills and training required for the deployment and operation of a new ZEB fleet. It also provides an assessment of potential technological, operational, and system-wide risks associated with the transition and a risk management plan that details mitigation strategies.
5. **Environmental Benefits:** Includes a lifecycle assessment of environmental benefits associated with the transition, including estimates of greenhouse gas (GHG) emissions reduction, noise reduction, and non-GHG pollutant reduction.

This Transit Fleet Zero Emission Transition Plan (Fleet Transition Plan) addresses each of these topics in the following report and the accompanying appendices.

---

<sup>3</sup> [Infrastructure Canada - Zero Emission Transit Fund Applicant Guide](#)



### 3 SYSTEM LEVEL PLANNING

The foundation of this Fleet Transition Plan begins with the approach to system-level planning. An analysis of ZEB technologies was performed to further understand both BEB and fueling options on the market for Milton Transit to consider. An energy consumption analysis was developed for Milton Transit to create an accurate energy profile, which further works to identify charging, refueling and facility requirements specific to the agency’s needs.

#### 3.1 BATTERY ELECTRIC BUSES & FUELING OPTIONS

BEBs are currently the most popular zero emission bus because they utilize the electric grid as a source of fuel, which is universally available and relatively “easy” to connect to for drawing the required power. One shortfall is the limited range of BEBs compared to conventional diesel buses; for agencies with longer range requirements, BEBs may not be capable of directly replacing buses assigned to long duty cycles at a one-to-one replacement ratio. In some cases, it’s not possible to adjust the service profile of these longer blocks to accommodate the range capabilities of today’s available BEBs. For extended range requirements, either additional vehicles become necessary or en-route charging would need to be introduced at layover points along current routes.

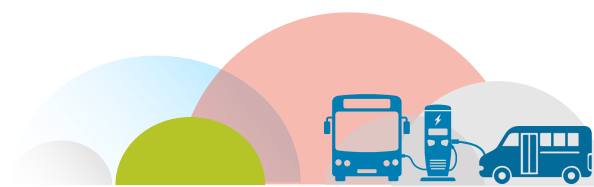
En-route charging is an enhancement that can greatly improve the feasibility of BEBs in many situations; it can extend the range of a BEB and facilitate one-to-one replacement of diesel vehicles when the routes are conducive to this charging strategy. This is particularly helpful with circular routes where the same en-route charger can be used by a vehicle multiple times throughout the day. En-route charging infrastructure would ideally be located at places such as transit centers where buses operating on multiple routes all have scheduled layover time.

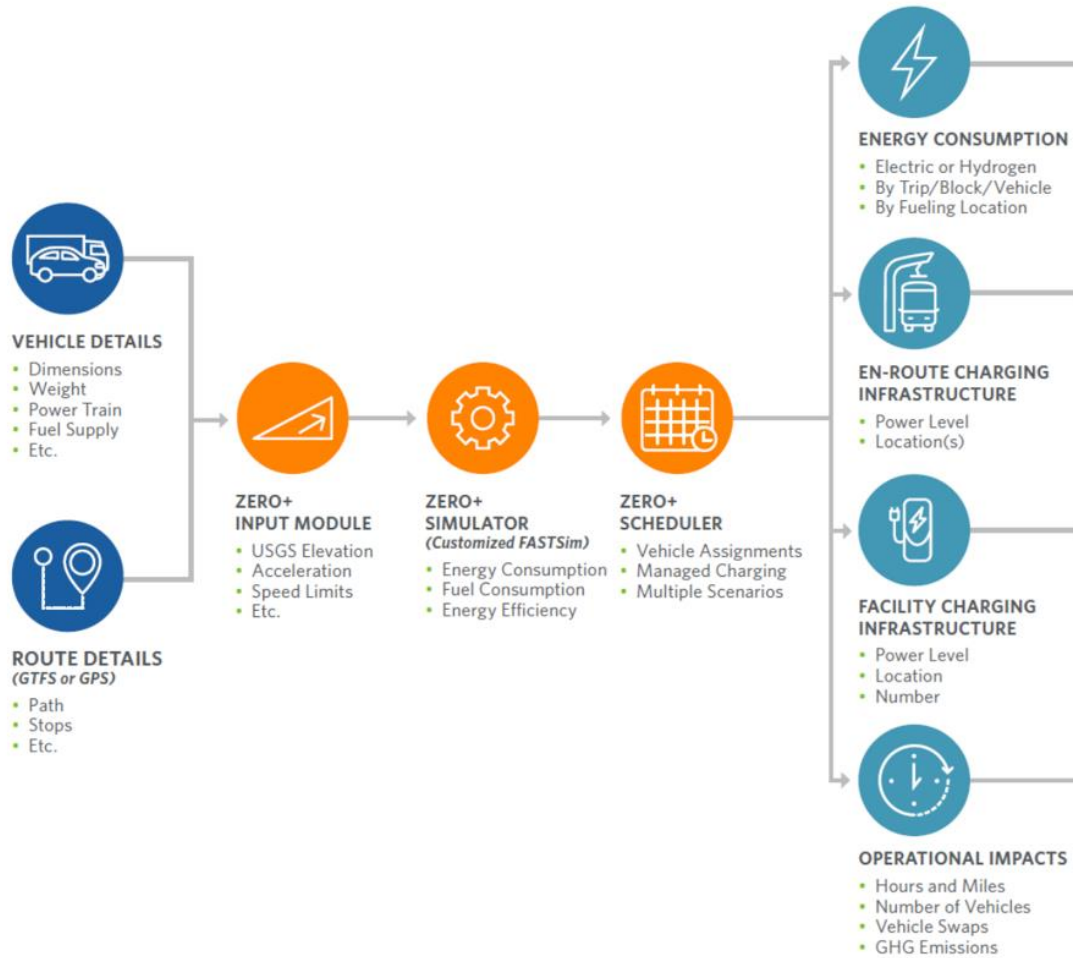
#### 3.2 ENERGY CONSUMPTION ANALYSIS

Understanding energy consumption is a key component of fleet transition planning, as it informs the choice of vehicle technology, infrastructure requirements, finances, and fleet replacement strategies. The following sections outline the methodology, modelled scenarios, and key findings of Milton Transit’s Energy Consumption Analysis.

##### 3.2.1 METHODOLOGY

Milton Transit’s zero emissions consultant, HDR, Inc. provided a comprehensive understanding of the potential impacts BEB technology may have on Milton Transit’s existing service using their proprietary energy consumption model, Zero+. **Figure 1** shows the Zero+ Model inputs, outputs, and process.





**Figure 1. Zero+ Inputs, Outputs, and Modelling Process**

Energy consumption is impacted by several factors including slope and grade of the bus routes, number of vehicle stops, anticipated roadway traffic, and ambient temperature. The Zero+ model also analyzes variables known to impact lifetime vehicle performance, like energy density, battery degradation, operating environment, HVAC and auxiliary power loads, as well as the lifecycle of bus batteries. The model is fed by GTFS data, GIS data, and vehicle profile assumptions to create an accurate energy consumption profile unique to Milton Transit’s existing service. In sum, Zero+ results include many data variables, yielding the most accurate results possible to influence strong, effective decision making.

The Zero+ model results, combined with discussions with Town staff, provide the basis upon which the preferred vehicle technology and refueling strategy will be determined. This modelling evaluated whether the optimal charging strategy is depot charging only or a mix of depot and en-route charging, which nameplate battery capacity and auxiliary heater type is optimal and identifies potential strategies that best complement Milton Transit’s service and fleet plans. Simulations were performed at the granular level to inform individual vehicles, routes, and blocks as well as the full Milton Transit fleet. Examining each vehicle individually drives decisions for the right technology at the system, depot, route, and block levels (e.g., how



vehicles are scheduled to operate in revenue service during the day). This analysis balanced impacts to operations, overall fleet size, and infrastructure requirements and ultimately provides Milton Transit with the information to make a data-driven determination of the preferred BEB technologies to deploy and the pace at which to deploy them.

### 3.2.2 MODELLED SCENARIOS

The energy consumption modelling effort included the analysis of five scenarios for the conventional 12m transit bus fleet, inclusive of the supplementary school service; the On-Demand and Milton Access+ services were also modelled. This analysis only considers Milton Transit's existing service operated by the current fleet and does not model any planned future fleet expansions, but criteria for the transition to BEBs on these planned expanded services will be provided as a guideline for Milton Transit to use when planning for a full BEB fleet. Once the new, expanded service profile is established, Milton Transit will need to consider conducting an additional fleet modelling study as a supplement to this plan to provide exact recommendations for a fleet transition to BEBs.

#### 3.2.2.1 FIXED-ROUTE TRANSIT FLEET

- Baseline (Diesel)
- Full BEB Fleet (525 kWh) with Depot Charging Only
- Full BEB Fleet (675 kWh) with Depot Charging Only
- Full BEB Fleet (525 kWh) with Depot and En-Route Charging

Based on the evaluation and collection of data described above, a baseline diesel scenario was simulated off current Milton Transit service to validate both the data provided and the functionality of the model by comparing simulation results to observed existing Milton Transit diesel operations. This validation provides confidence that the simulations of BEB scenarios are not missing critical data points that influence the transition.

Depot charging only was modelled first to establish a baseline feasibility. This scenario allows the Zero+ Model to identify which existing service blocks can be electrified without an increase in peak vehicle requirements, the need for en-route charging, or the need for schedule modifications to achieve the same level of service. In the depot charging only scenario, the model indicates how many additional vehicles would be required to maintain the same level of service without the use of en-route charging.

The model also included the analysis of a scenario where Milton Transit utilizes a combination of depot and en-route charging. Layover times in the existing schedule were used to identify the most ideal locations for en-route chargers; the Milton GO Station was identified as an ideal en-route charging location. It should be noted that although this location was modelled, the Town does not currently own this property which would be a contingency for installing and operating en-route chargers at this location. The Town should explore coordination with Metrolinx, the current property owner of the Milton GO Station, to install chargers that could be jointly operated by Milton Transit and GO Transit in anticipation of needing en-route charging capacity. Alternatively, Milton Transit could also consider delaying en-route charging plans until the planned service expansion is complete; through service expansion, additional candidate sites for en-route charging may be identified. Based on modelling of the existing fixed route service, the decision to implement en-route charging infrastructure at the Milton GO Station would need to be made at the beginning of Phase 2B with the purchase of the 12<sup>th</sup> BEB in 2029.



### 3.2.2.2 PARATRANSIT AND SPECIALIZED FLEET

Milton Transit's On-Demand and Access+ services were modelled separately from fixed route services due to the available data types. This modelling effort was based on operating data provided by the agency as well as the battery and charging specifications of equivalent BEBs. Existing paratransit and specialized fleet vehicles' average and maximum daily kilometres and hours in service, derived from Milton Transit's monthly vehicle data, were considered in the modelling. The total energy consumption of the BEB fleet is computed using the worst-case vehicles to forecast overall site energy and fleet size impacts.

If the daily amount of energy required exceeds the available energy for a vehicle, then the cases for an increase in fleet size or mid-day fast charging are considered. These additional cases facilitate protecting the vehicle's health while avoiding interruptions to normal operations. Three scenarios were considered: a base scenario, a scenario reflecting an expanded BEB fleet, and a scenario where the fleet is not expanded but mid-day recharging is supported.

### 3.2.3 KEY TAKEAWAYS

For conventional services, a 675kWh BEB fleet with depot only charging is operationally advantageous for Milton Transit as this scenario would require vehicle swaps (e.g. exchanging a BEB vehicle that has reached the daily operational limit for the battery capacity, with a BEB vehicle that is fully charged at the depot). These vehicle swaps would be required for four service blocks, while all other blocks are feasible without swaps. Under a 525kWh BEB fleet with depot only charging scenario, seven service blocks would require a vehicle swap. Fewer vehicle swaps are recommended for the following reasons:

- **Operational efficiency**
  - Fewer vehicle swaps result in lower non-revenue hours and miles to swap out vehicles during service, minimizing potential service disruptions.
  - Necessity for vehicle swaps may require additional drivers.
- **Cost savings**
  - More vehicle swaps result in a larger increase in fleet size requirements.
  - Increased fleet sizes also require additional charging equipment, depot space, and maintenance resources.
  - Swaps require vehicles to return to the garage midday for charging, incurring higher utility rates compared to overnight charging with lower utility rates, contributing to higher operational costs.

While a combination of depot and en-route charging would mean that all Milton Transit service blocks could be operated without vehicle swaps or changes to service, the complexities of infrastructure management, property ownership, and coordination at the identified feasible en-route charging location, the Milton GO Station, make Milton Transit's preferred scenario depot only charging with 675kWh BEBs.

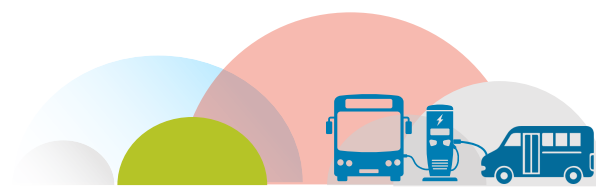
Milton Transit's specialized fleet for on-demand services was modelled iteratively to determine the best alternative for the Town since vehicles cannot be transitioned at a one-to-one replacement ratio without some fleet and/or service modifications necessary. Milton Transit will elect to utilize mid-day recharging of the specialized fleet rather than expand the fleet. Nearly all existing vehicles can complete existing service on an average day without the need for service modifications, and all vehicles can complete service on both





average and worst-case days with mid-day recharging. Since the worst-case operational profile is not regularly realized, the Town will operate BEBs on existing service with plans to utilize existing DCFCs installed at the depot for fixed route buses as a contingency if daily use is anticipated to exceed the operational range of the BEBs.

The detailed results of the route modelling analysis for Milton Transit's fixed route, On-Demand, and Access+ transit services can be found in **Appendix A: Energy Modelling Analysis**.



## 4 OPERATIONAL PLANNING & DEPLOYMENT

The following components highlight critical fleet and infrastructure implementation needs, including actions that will be taken to effectively deploy BEBs and ensure efficient future operations. The fleet deployment plan highlights each phase of the plan, offering a purchase schedule and insight into the phased deployment effort using the current transit fleet growth and replacement forecast provided by Town staff. The facility and infrastructure plan for the prospective depot facility is also provided, covering existing conditions and facility infrastructure implementation. The feasibility of en-route charging is also considered, with potential locations Milton Transit may consider to assessing in the future.

### 4.1 FLEET DEPLOYMENT PLAN

Milton Transit will be launching a BEB Pilot Program in early 2024 with one repowered bus (a diesel bus retrofitted with an electric drivetrain). The pilot will provide real-world experience with operating and managing an alternative-powered vehicle. Over time, and subject to Council approval of the Transit Fleet Zero Emission Transition Plan and associated budget, new BEBs are to be gradually introduced, with the first procurement anticipated in 2025 to be delivered and enter revenue service in 2027, two years from the purchase date. Initially, Milton Transit will integrate BEBs to the fixed route fleet with half of the buses purchased in each year to be BEBs and the other half to be diesel. Beginning in 2029, Milton Transit will cease purchasing diesel buses for fixed route service and all future procurement will be battery electric. The on-demand/specialized fleet transition will begin in 2026 with the purchase of three 6m buses. Similar to the fixed-route fleet, half of the buses purchased in each year will be battery electric until 2029; beginning in 2030, all future procurements will be battery electric.

#### 4.1.1 FIXED ROUTE TRANSIT FLEET

The fixed route fleet will be electrified in three phases based upon infrastructure needs at the depot facility, available vehicle battery capacity, and future service expansion. The BEB in service through the Pilot Program will have a battery capacity of 400 kWh, while all future BEBs purchased from the OEM will be 675 kWh.

##### **Phase 1: BEB Pilot Program (2024)**

Milton Transit will pilot one repowered diesel BEB to test the technology and its impacts on ongoing service and operations. The Pilot BEB will rotate operating on all existing service routes to test how the bus performs on different route profiles.

##### **Phase 2: Electrify Existing Fixed-Route Service (2025-2030)**

Milton Transit currently operates seventeen (17) buses on existing active service. This phase will include the purchase of twenty-six (26) buses; sixteen (16) of these buses will be battery electric, completing the electrification of existing active fleet.

##### **Phase 2A: 50% of procurements in each year will be BEB (2025-2028)**

During this phase, Milton Transit will purchase sixteen (16) buses that will be a mix of diesel and battery electric buses; half of new procurements will be diesel (8 buses) and the other half will be BEB (8 buses).



**Phase 2B: 100% of procurements in each year will be BEB (2029-2030)**

Beginning in 2029, Milton Transit will cease purchasing diesel buses and all future procurements will be BEB. In this phase, ten (10) BEBs are purchased bringing the fleet total to forty (40) buses, including planned service expansion growth buses.

**Phase 3: Electrify Expanded Fixed Route Service (2031-2040)**

During this phase, Milton Transit will transition the remainder of the existing and planned expanded fleet to BEBs. BEB replacements of diesel buses purchased in phases 1 and 2A are also included in this phase, bringing the fixed-route transit fleet to a total of forty-five (45) buses in 2033 (delivery in 2035) with a full transition to BEBs occurring in 2038 (delivery in 2040).

**Table 3** provides a breakdown of the number of fixed route BEBs purchased in each phase, with delivery of buses anticipated *two years after they are purchased*.

**Table 3. Phased Fixed Route Fleet Deployment Plan**

Phase	Purchased Replacement BEBs	Purchased Growth BEBs	Cumulative Purchased BEBs	Purchase Year
<b>Phase 1</b>	1	-	1	2024
<b>Phase 2A</b>	-	7	8	2025 – 2028
<b>Phase 2B</b>	6	3	17	2029 – 2030
<b>Phase 3</b>	23	5	45	2031 – 2040

**Table 4** shows which purchases are replacement buses, where a diesel bus will be retired upon delivery, and expansion buses, where fleet size increases and a vehicle is not retired upon delivery. In many years, there are a mix of replacement and expansion buses. The breakdown aligns with the Town’s expected 2023-2033 Transit Fleet Growth, Replacement, and Mid-Life Refurbishment Schedule.

**Table 4. Bus Procurement Schedule, Replacement and Expansion Breakdown (2023 - 2040)**

	2023	2024	2025	2026	2027	2028	2029	2030	2031	2032	2033	2034	2035	2036	2037	2038	2039	2040
Diesel – Expansion Bus		4	4	3	1	1												
Diesel – Replacement Bus	5	2																
Electric – Expansion Bus			2	3	1	1	2	1	2	1	2							
Electric – Diesel Replacement Bus		1*					2	4	2	1			5	6	4	3	1	1
Electric – Electric Replacement Bus**								1							2	3	1	1

\*Diesel conversion pilot BEB

\*\*BEB replacement of BEB purchased earlier in transition



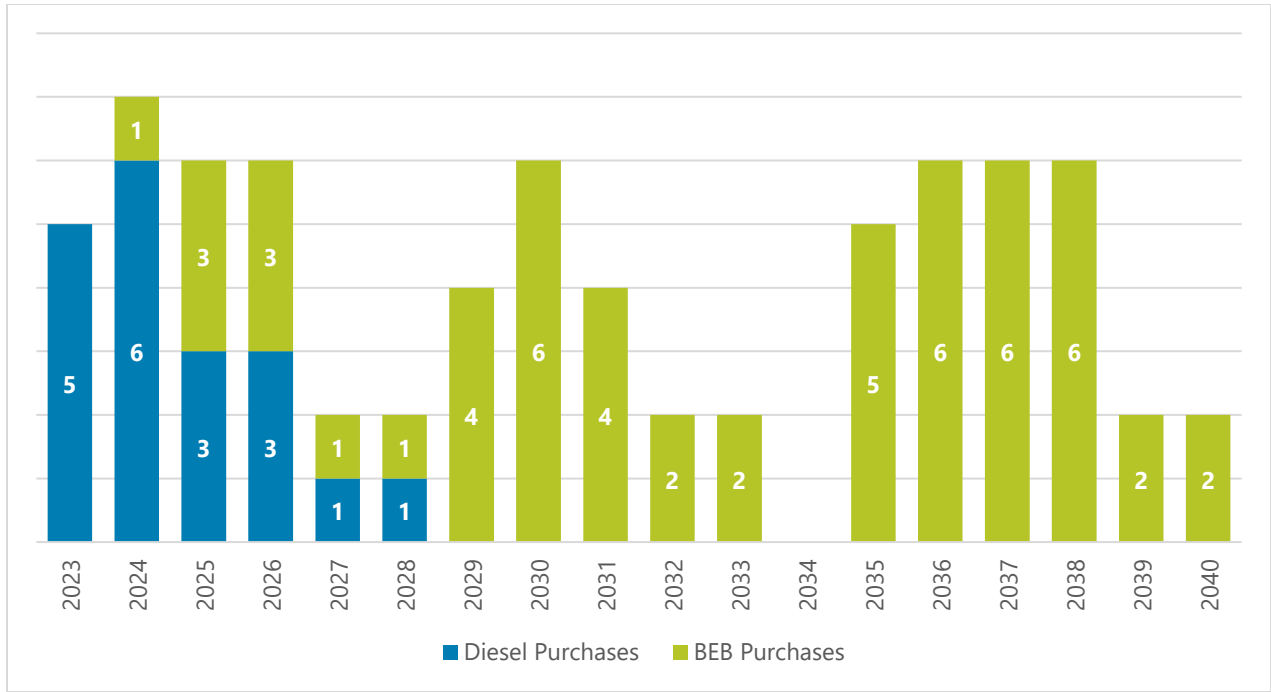


Figure 2 shows when new fixed route buses, both diesel and BEB, will be purchased through 2040, while

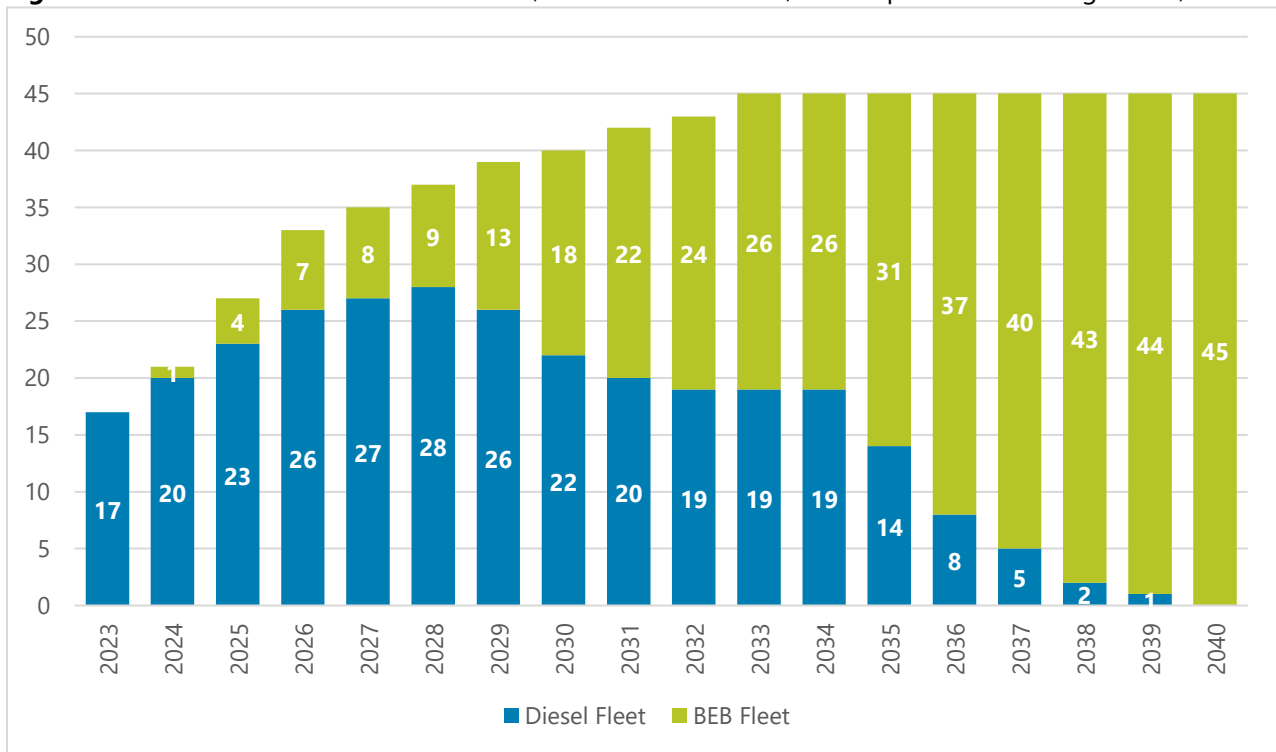
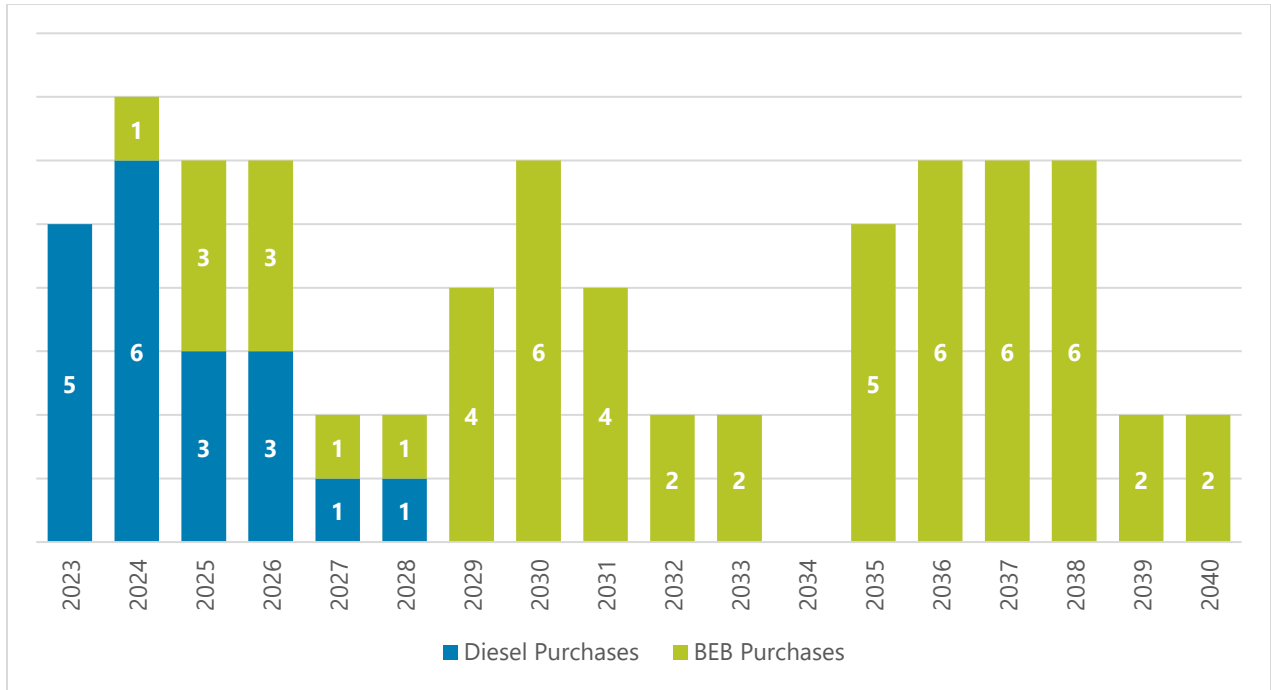
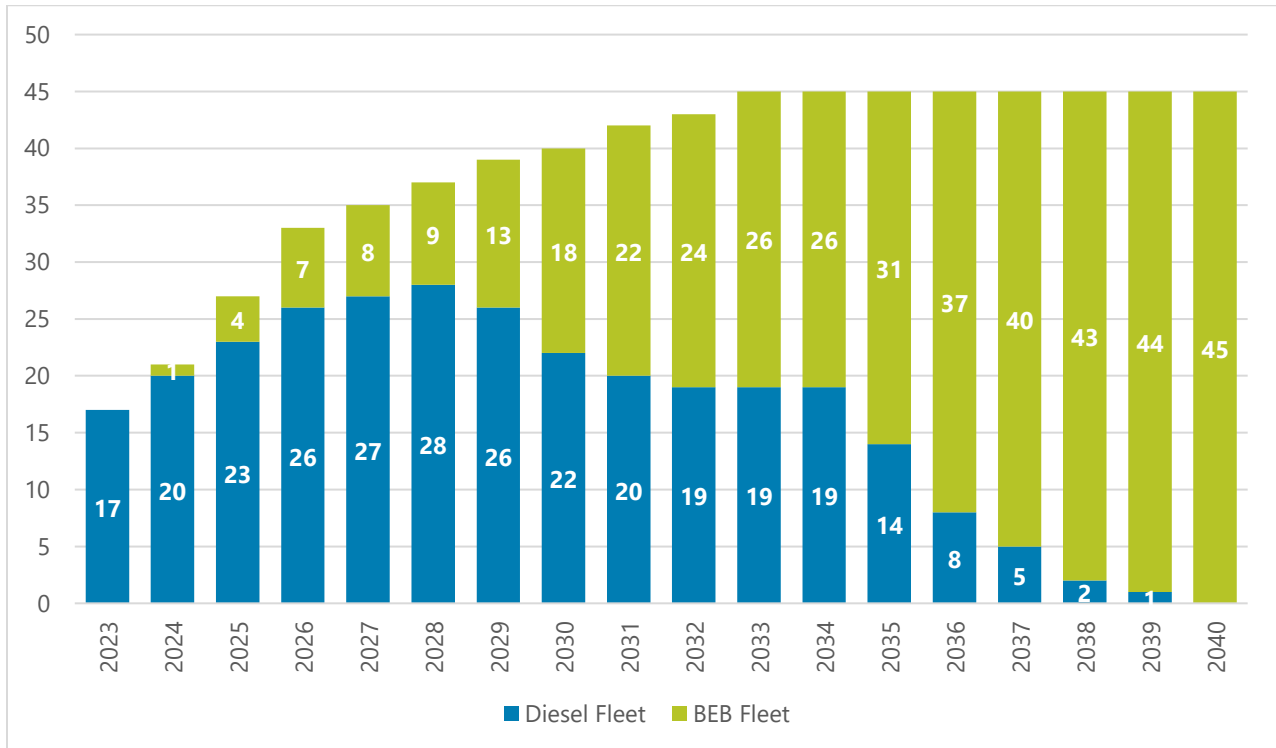


Figure 3 provides a visual representation of the fixed route fleet makeup throughout the planning period.

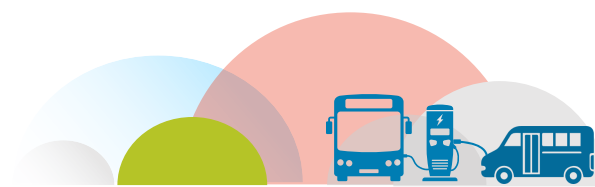




**Figure 2. Fixed Route Transit Fleet Procurement Schedule (2023-2040)**



**Figure 3. Fixed Route Transit Fleet Composition by Purchase Year (2023-2040)**



### 4.1.1.1 FUTURE SERVICE CRITERIA

Milton Transit will begin by electrifying the fleet and operate service with depot charging only during Phases 1 and 2, where only one additional vehicle is required without the need for or en-route charging. In Phase 3, with the expanded service, either a fleet expansion or en-route charging infrastructure would likely be necessary to maintain the same level of service as diesel operations. Because the nature of the expanded service is unknown, the exact vehicle requirement to support this new service cannot be predicted. **Table 5** outlines the feasibility criteria for expanded service; the feasible distance for a 1:1 conversion is the maximum duty cycle distance a 675 kWh BEB can complete without the need for bus swaps or en-route charging.

**Table 5. Expanded Service Feasibility Criteria**

	Easiest Route	Average Route	Hardest Route
<b>Average Vehicle Efficiency</b>	1.3 kWh/km	1.60 kWh/km	1.97 kWh/km
<b>Feasible Distance for 1:1 Conversion</b>	Up to 330 km	Up to 270 km	Up to 220 km

The longest duty cycle in the Town’s current service profile is 400 km, so in any case expanded service could be completed with at most one swap per duty cycle. “Easiest” refers to the most energy efficient route (i.e., least number of stops, flattest terrain, etc.), while “hardest” refers to the least energy efficient route (i.e., many stops, difficult/steeper terrain, etc.). If expanded service exceeds 330 km, either en-route charging or additional vehicles to facilitate bus swaps would be required.

### 4.1.2 ON-DEMAND/SPECIALIZED TRANSIT FLEET

The on-demand/specialized fleet will follow a similar phasing approach as the fixed route, but with different years of implementation. No specialized fleet vehicles will be replaced during Phase 1, but Phase 2A will include electrification of half the replacement vehicles between 2025 and 2028. Phase 2B will occur in 2029 and 2030 where all new vehicle purchases will be electric to maintain the existing fleet size. Phase 3 will increase the number of 6-metre vehicles to expand service and replace remaining gasoline vehicles.

#### Phase 1: Internal Combustion Only (2023-2025)

In Phase 1, Milton Transit will not purchase any battery electric on-demand/specialized fleet vehicles, all procurements will be gasoline.

#### Phase 2: Mixed Fleet (2026-2027)

During this phase, Milton Transit will purchase a mix of gasoline and battery electric vehicles. In each year, half of the procurements will be gasoline and the other half will be battery electric.

#### Phase 3: Full Fleet Electrification (2028 – 2034)

Beginning in 2028, Milton Transit will cease purchasing gasoline vehicles and all future procurements will be battery electric. The transition of both the 6- and 8-metre fleets will be complete in 2034 with a total fleet of seventeen (17) 6m buses and (6) 8m buses.

**Table 6** provides a summary of the fleet composition by vehicle size and fuel type at the end of each phase.



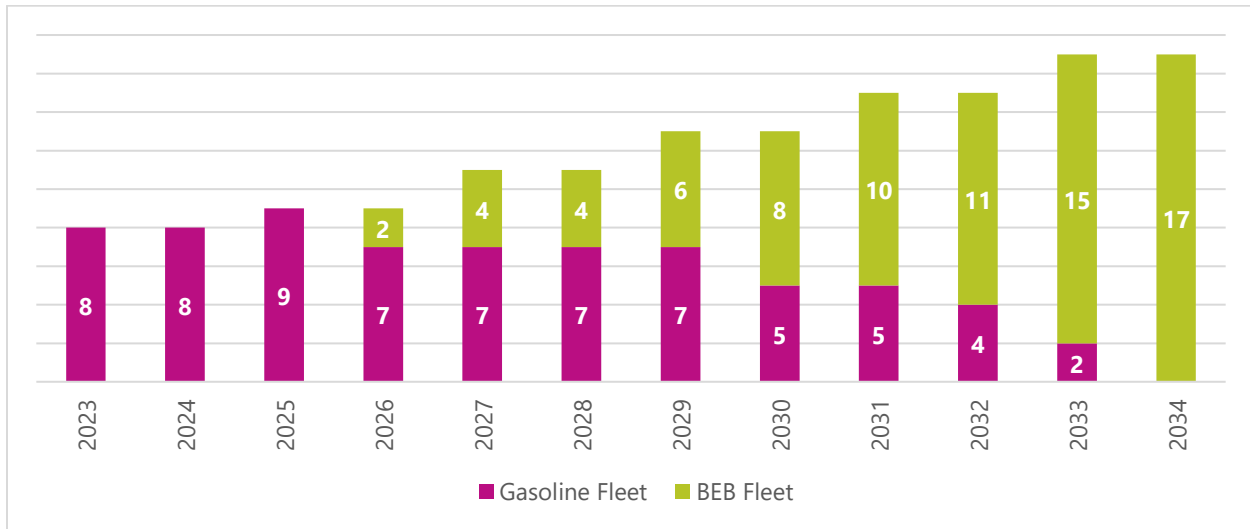
**Table 6. Phased Specialized Fleet Composition by Phase**

Phase	6M Gas Fleet Count	6M BEB Fleet Count	8M Gas Fleet Count	8M BEB Fleet Count	Purchase Year
Phase 1	9	-	6	-	2023 - 2025
Phase 2	7	4	5	1	2026 - 2027
Phase 3	-	17	-	6	2028 - 2034

The fleet composition by year for 6-metre and 8-metre specialized vehicles are shown in **Figure 4** and **Figure 6**, respectively, through 2034.

#### 4.1.2.1 6-METRE SPECIALIZED FLEET

The transition of the 6-metre specialized fleet will begin in 2026 with the purchase of 2 BEBs; the following years include the purchase of a mix of gasoline and electric buses, with the Town of Milton ceasing gasoline purchases after 2027 and reaching 100% BEB in 2034. A progression of the 8-metre fleet composition throughout the transition is shown below in **Figure 4**.



**Figure 4. 6M Specialized Fleet Composition by Purchase Year (2023-2034)**

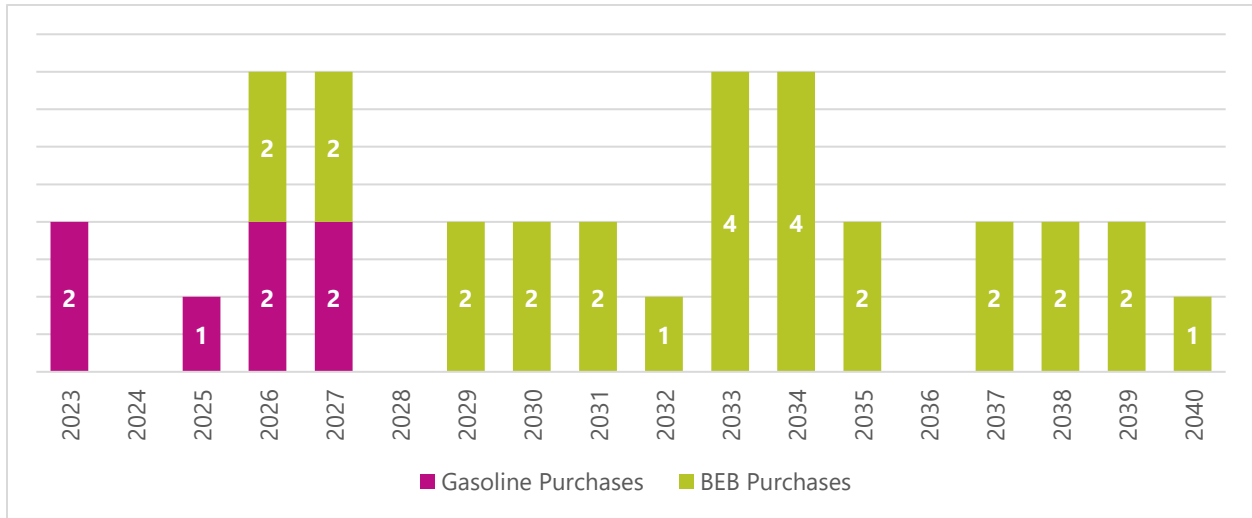
**Table 7** shows which purchases are replacement 6-metre buses, where a gas-powered bus will be retired upon delivery, and expansion buses, where fleet size increases and a vehicle is not retired upon delivery; in many years, there are a mix of replacement and expansion buses. Purchases of replacement BEBs are further broken down to differentiate between which are replacements of gasoline buses and which are replacements of BEBs purchased earlier in the transition. The breakdown aligns with the Town’s expected 2023-2033 Transit Fleet Growth, Replacement, and Mid-Life Refurbishment Schedule.



**Table 7. 6M Specialized Fleet Procurement Schedule, Replacement and Expansion Breakdown (2023 - 2040)**

	2023	2024	2025	2026	2027	2028	2029	2030	2031	2032	2033	2034	2035	2036	2037	2038	2039	2040
Gasoline - Growth Bus	2		1		1													
Gasoline - Replacement Bus				2	1													
BEB - Growth Bus					1		2		2		2							
BEB – Gas Replacement Bus				2	1			2		1		2						
BEB – Electric Replacement Bus											2	2	2		2	2	2	1

**Figure 5** summarizes the information from the table above and shows the total number of 6-metre buses purchased in each year by fuel type through 2040.



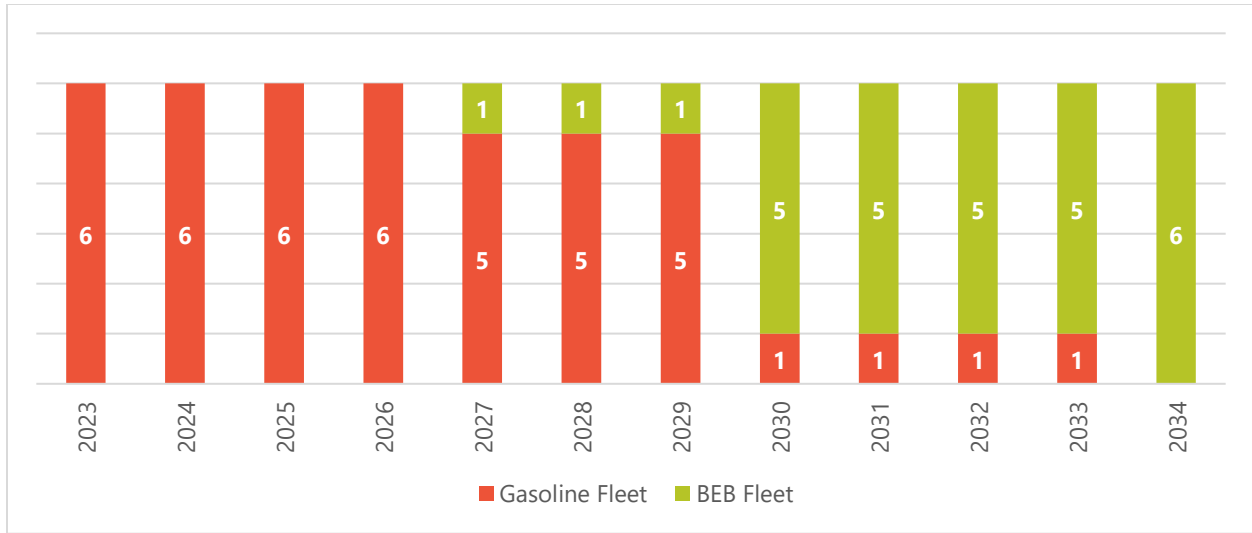
**Figure 5. 6M Specialized Fleet Bus Procurement Schedule by Fuel Type (2023-2040)**

### 4.1.2.2 8-METRE SPECIALIZED FLEET

The transition of the 8-metre specialized fleet will begin in 2027 with the purchase of 1 BEB; the following years include the purchase of a mix of gasoline and electric buses, with the Town of Milton ceasing gasoline purchases after 2027 and reaching 100% BEB in 2034. A progression of the 8-metre fleet composition throughout the transition is shown below in **Figure 6**.







**Figure 6. 8M Specialized Fleet Composition by Purchase Year (2023-2034)**

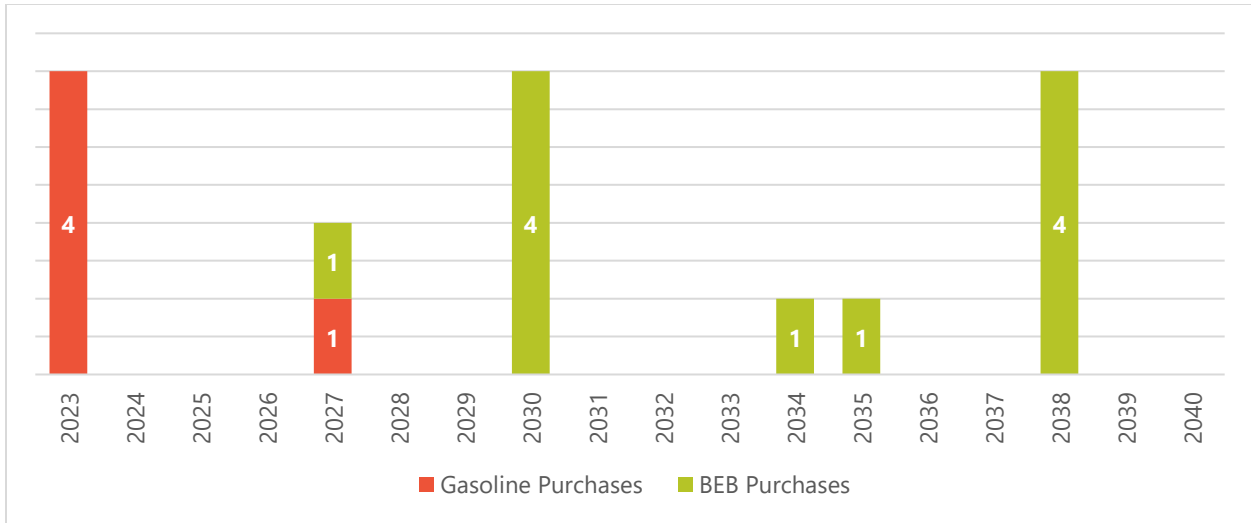
**Table 8** shows which purchases are replacement 8-metre buses, where a gas bus will be retired upon delivery, and expansion buses, where fleet size increases and a vehicle is not retired upon delivery. Purchases of replacement BEBs are further broken down to differentiate between which are replacements of gasoline buses and which are replacements of BEBs purchased earlier in the transition. The breakdown aligns with the Town’s approved 2023-2033 Transit Fleet Growth, Replacement, and Mid-Life Refurbishment Schedule.

**Table 8. 8M Specialized Fleet Procurement Schedule, Replacement and Expansion Breakdown (2023 - 2040)**

	2023	2024	2025	2026	2027	2028	2029	2030	2031	2032	2033	2034	2035	2036	2037	2038	2039	2040
Gasoline - Growth Bus	2																	
Gasoline - Replacement Bus	2				1													
BEB - Growth Bus																		
BEB – Gas Replacement Bus					1			4				1						
BEB – BEB Replacement Bus													1			4		

A summary of the total number of 8-metre buses purchased in each year by fuel type through 2040 is provided below in **Figure 7**.





**Figure 7. 8M Specialized Fleet Bus Procurement Schedule by Fuel Type (2023-2040)**

### 4.1.3 SOFTWARE SYSTEMS

Introducing BEBs will introduce additional variables that Milton Transit plans to monitor, such as dynamic vehicle scheduling, vehicle battery health, charger health and energy management. There are several software packages available for transit agencies to monitor vehicles and chargers live and retroactively; some may be available from OEMs and others are third party software packages that Milton Transit would acquire independently from vehicle or charger procurements.

- **Vehicle Monitoring Systems** – Milton Transit will consider this software in order to provide constant monitoring and logging of all vehicle data transmitted by BEBs. This information can be critical to quickly identify mechanical component or hardware failures and expedite maintenance repairs. Some OEMs offer this software as part of the rolling stock procurement, but other third-party vendors may be preferred as they are typically manufacturer agnostic which would allow Milton Transit to view all vehicles in the same interface regardless of bus manufacturer. The interface should include vehicle telematics information including energy consumption, battery state of charge, and vehicle propulsion efficiency that can all be used to evaluate vehicle performance for future procurements.
- **Charging and Energy Management Systems** – Milton Transit will consider using this software schedule and manage charge sessions between different vehicles; this can provide a significant operational cost savings through demand peak shaving. This optimize costs where utility rates are priced in a time of use utility rate structure. Some providers offer options with additional functionality like management of other energy resources like battery energy storage and solar generation.
- **Digital Yard Management Systems** – Milton Transit will consider using this software to help staff know which buses are ready or not ready for service. Tools are now available that allow staff to know the real time location and status of vehicles in the yard. Some solutions can also help by



providing parking information for the vehicle depending on the status and state of charge (SOC) of the vehicle. For example, a digital sign at the entrance of the facility could let drivers know based on vehicle information to park vehicles that are required to be held of scheduled maintenance in one area, vehicles with high SOC that can go back into service in another area and vehicles with low SOC that need more time to charge in a different area. This tool could also be shared with operations to let them know where vehicles are parked in the yard, whether a given vehicle is ready for service and/or if a substitution needs to be made.

- **Scheduling Software** – Milton Transit will consider procuring this software to help ensure BEB fleet vehicles assigned to routes are fully charged by the time they are due to pull out of the garage for revenue service. In many cases, this software can be tied into charge management and digital yard management system interfaces so that dispatchers can see the current vehicle state of charge when assigning vehicles to service blocks. In some cases, this can also provide an operational safeguard if a dispatcher attempts to assign a BEB to a block that exceeds the vehicle’s capable range, reducing the probability of needing to do in-service bus swaps.

It is important to note that the Town is currently piloting a telematics software system as part of the diesel-to electric bus conversion pilot project through the Town’s current Transit ITS/AVL vendor Consat Canada. Upon conclusion of the pilot, the Town may consider leveraging this software system to include BEB and charging infrastructure systems, subject to performance and meeting minimum requirements for vehicle monitoring, charging and energy management, yard management and scheduling systems.

## 4.2 FACILITY & INFRASTRUCTURE PLAN

Milton Transit does not currently operate out of an owned transit facility but is in the planning stages of designing a new facility for transit operations. This transition focuses on evaluating charging infrastructure to be implemented at this future new depot facility as well as the potential to install en-route charging infrastructure at the Milton GO Station.

### 4.2.1 MILTON CIVIC OPERATIONS CENTRE

The Town currently has a single ABB 150kW plug-in depot charger with one dispenser installed at the Milton Civic Operations Centre, a municipal facility owned by the Town. This charger will be used to support the BEB Pilot Program; this single BEB will transition to the future Milton Transit Depot Facility once constructed.

### 4.2.2 FUTURE MILTON TRANSIT DEPOT FACILITY

Milton Transit will electrify the future Milton Transit Depot facility for both the fixed route and on-demand/specialized fleets in three phases shown below in **Figure 8**; this conceptual layout is a representative plan of what a future transit facility could look like when factoring in the space requirements for different functions.

Most BEB charging typically occurs at transit depots while the buses are idle. Bus charging can take several hours depending on the state of charge, but not every bus will require a long charge period. Since charging will be implemented in phases, it is important that charging is planned to limit interruptions to service when installing future phases.



The site plan accommodates a large increase of buses through 2040 and must also accommodate a mixed fleet of BEB and ICE vehicles. **Figure 8** shows the buildout conditions for where the on-demand/specialized vehicles are housed in the south portion of the future Milton Transit Depot Facility and the fixed route buses are housed in the north portion.

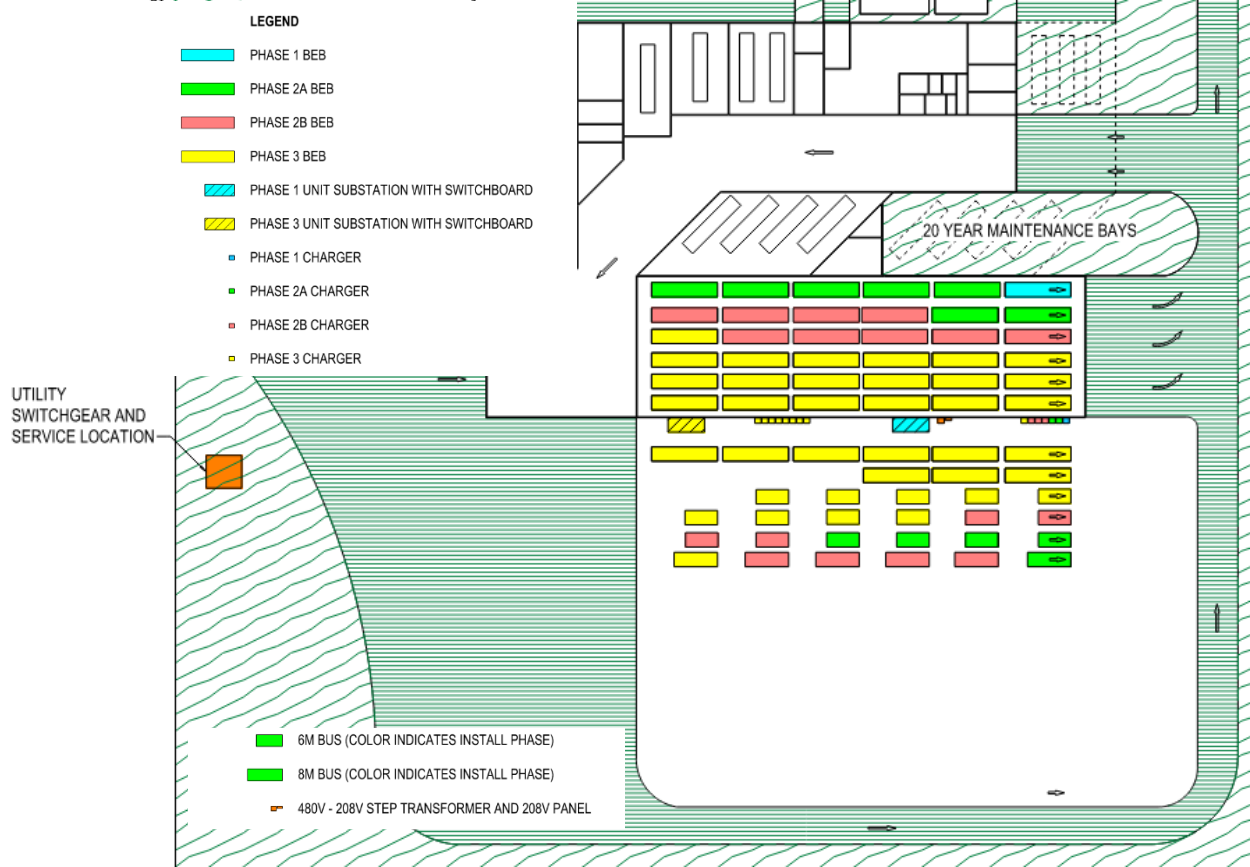
The vehicles are largely separated by the indoor chargers and electrical equipment. Placing the chargers indoors will provide easier maintenance and longer life than if they were exposed to harsh outdoor winter conditions. One DC fast charger will be connected to up to three dispensers/fixed route buses. Since the on-demand/specialized buses have smaller batteries and travel less miles, these vehicles will utilize Level 2 charging, though they can still connect to DCFCs typically used for the fixed route buses if they need an occasional quick charge.

**Phase 1** shall not require the installation of any additional chargers. The single 150 kW ABB charger installed at the Milton Civic Operations Centre will accommodate the single Pilot Program BEB to be delivered in 2024.

**Phase 2** shall require the installation of (6) 150 kW plug-in chargers with 3 dispensers each at the future Milton Transit Depot Facility to support the Phase 1 Pilot BEB and additional (16) 675 kWh BEBs to be delivered by 2030. This phase will also include the installation of (13) 7.2 kW Level 2 AC chargers to support (8) 6-metre cutaways and (5) 8-metre cutaways. These chargers will all be powered by a new unit substation installed in 2025.

**Phase 3** shall require the installation of (9) 150 kW plug-in DCFCs with 3 dispensers each at the future Milton Transit Depot Facility to support (28) additional 675 kWh to be delivered between 2031 and 2040. An additional (10) 7.2 kW Level 2 AC chargers will also be installed in this phase to support (1) additional 8m BEB and (9) additional 6m BEBs.





**Figure 8. Milton Transit Facility Conceptual Site Plan**



### 4.2.3 VEHICLE CHARGING AT FUTURE TRANSIT FACILITY

- Milton Transit will install one dispenser per bus bay to allow for charging of vehicles without the need to host buses.
- Milton Transit will avoid ground mounting of the dispensers where possible due to the significant space required. The bus storage area is expected to be indoors so dispensers could be either ceiling mounted pantographs or retractable plug-ins depending on the agency's preference.
- If pantograph dispensers are specified, some plug-in dispensers should still be included. Locations closest to the wall are shown as wall-mounted plug-in dispensers.
- Phase 2 and Phase 3 include capacity for smaller electric cutaway buses that can only accept plug-in charging. Milton Transit will consider installing an island between the lanes for those locations in Phases 2 and 3 to site the smaller plug-in dispensers (Level 2) which may not be able to be ceiling mounted.
- With the current facility plan, the charging cabinets are located indoors and take up potential bus parking stalls. As this will be a new building, locating the charging and electrical infrastructure above the parking area is an option that Milton Transit will explore during design. A mezzanine level for charging infrastructure could shorten cable runs and keep charging infrastructure out of the way of bus traffic.

### 4.2.4 FUTURE EN-ROUTE CHARGING LOCATIONS

En-route charging is typically installed at terminus locations where vehicles layover between runs and already have time in the schedule to charge. Because transit agencies often locate stops on public streets or on properties that are owned by third parties, it can be difficult to find space to install charging infrastructure at those locations. Milton Transit will prioritize en-route charging locations where the agency already owns property or will engage with those property owners to understand if agreements can be reached to locate infrastructure at those sites.

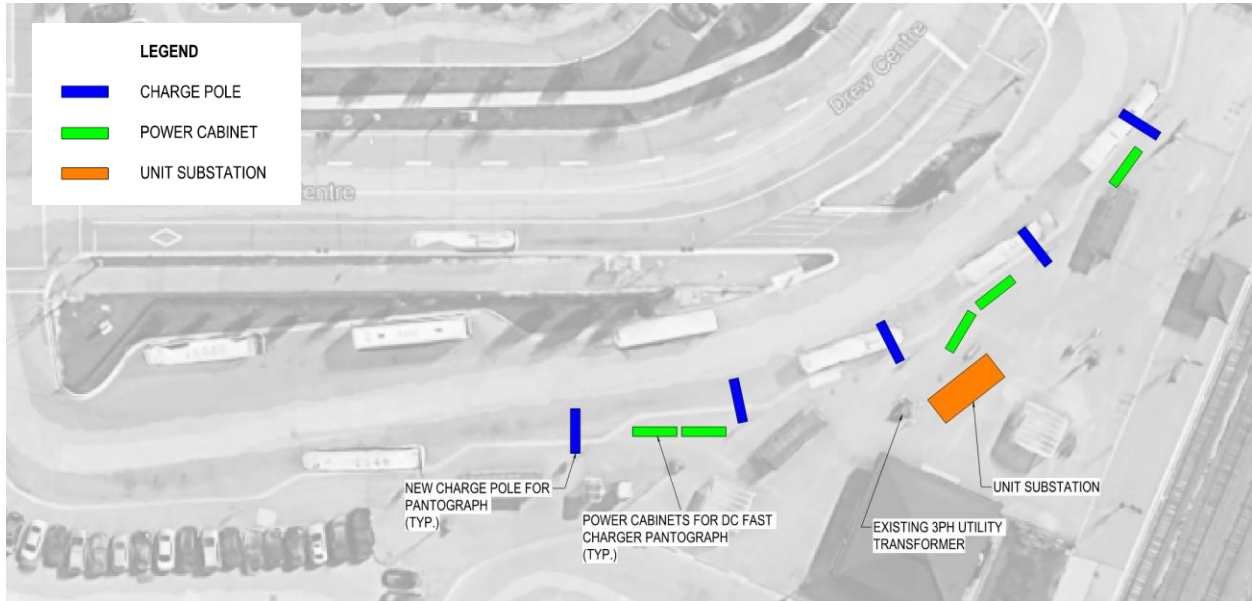
The Town does not currently intend to proceed with en-route charging but will re-evaluate closer to 2030 based upon the vehicle battery technology available, en-route charger performance of other nearby agencies, and relationships with landowners of potential en-route charging locations.

#### 4.2.4.1 MILTON GO STATION

The Milton GO Station has been identified as the primary location for en-route charging; this location is ideal for this use because all fixed route service begins and ends here. Located at 780 Main Street East, buses enter from Drew Centre Access Road and park in a sawtooth pattern depending on route assignment as shown in **Figure 9**. Milton Transit uses seven of the twelve bus bays closest to the rail line, including three landing pads on Drew Centre Access Road. GO Bus service occupies the remaining five bays. The right lane on SE-bound Drew Centre Access Road is designated as a bus only lane with signs and pavement markings.<sup>4</sup>

<sup>4</sup> [2019-2023 Milton Transit Services Review & Master Plan Update](#), page 32





**Figure 9. Milton GO Station Aerial View**

Milton GO Station serves as Milton Transit’s transfer hub, allowing passengers to transfer among bus routes as well as GO commuter rail and bus services. The facility’s current layout is not large enough to accommodate all eight routes at the same time, the Town has tentative plans to redevelop this site layout which may significantly impact gate locations in the future necessary to serve Milton Transit’s existing service and future service growth through 2031. If Milton Transit ultimately decides to proceed with en-route charging, all planning and construction activities will not commence until any site redevelopments are finalized.



## 5 CAPACITY TO IMPLEMENT THE TECHNOLOGY

In this section of the plan, Milton Transit’s resources, skills and training required for the deployment and operation of a new ZEB fleet are evaluated to develop a staffing and training plan equipped to the agency’s needs. An assessment of potential technological, operational, and system-wide risks associated with the transition and a risk management plan that details mitigation strategies is also provided.

### 5.1 STAFFING & TRAINING PLAN

With the introduction of battery electric technology to the Town’s transit fleet, proper training on bus systems and subcomponents unique to BEBs is critical to ensure safe, efficient operation and maintenance of the transitioned fleet. As Milton Transit begins to bring vehicle maintenance in-house with the completion of the future Milton Transit Depot facility, the agency will work with the current contract operator and other external training programs while in close coordination with OEMs and neighboring transit agencies to acclimate the existing workforce to the new technology, avoiding any displacement of the existing workforce.

This section will address the necessary steps to evaluate the skills of the existing workforce, identify skill gaps on an individual basis, and develop a plan to build and implement an effective training program for bus operators and bus maintenance personnel. In addition to the further development of the existing workforce, this chapter will also convey a workforce growth strategy for attracting new employees, retaining new and current employees, and funding opportunities to sponsor the required growth.

If the Town elects to continue outsourcing maintenance services for the fixed route and/or on-demand/specialized fleets, this section could be utilized to create technical specifications and establish minimum training standards and requirements. These standards and requirements can then be considered for inclusion in any subsequent RFPs for contracted services.

#### 5.1.1 SAFE WORKPLACE POLICY AND STANDARDS

In Ontario, employers have a legal obligation, through the Occupational Health and Safety Act, R.S.O. 1990 (OHSA) to develop and implement a workplace safety program that ensures the health and safety of their workers. This includes a written policy, hazard identification and control, worker training, worker involvement in program development, procedures for accidents and illness, and regular review and updates. Failure to comply with the OHSA can result in harm to workers and penalties for the employer.

The Canadian Standards Association (CSA) developed [CSA Z462:21](#), an electrical safety standard for Canadian workplaces to prevent electrical injuries and fatalities. It provides guidelines and requirements for identifying and assessing electrical hazards, selecting, and using personal protective equipment (PPE), establishing safe work procedures, and training workers. CSA Z462:21 is updated periodically to reflect changes in technology, regulations, and best practices. The standard is widely adopted in Canada by a variety of industries where electrical hazards exist, including manufacturing, construction, and utilities.

CSA Z462:21 is largely based on its American counterpart, developed by the National Fire Protection Association (NFPA), called [NFPA 70E](#). Both standards are focused on fixed electrical infrastructure (such as charging infrastructure) and do not directly address “mobile” high-voltage systems such as the battery drivetrains in battery electric vehicles. Transit agencies are identifying principles from these standards to





apply to battery electric workplaces, and it is possible that updated versions of the standards will include consideration of battery electric vehicles.

### 5.1.1.1 PERSONAL PROTECTIVE EQUIPMENT (PPE)

Personal Protective Equipment (PPE) is designed to protect users from health and safety hazards. PPE must be implemented when elimination, substitution, engineering and administrative controls fail to reduce or remove hazards.<sup>5</sup>

Under Canadian and Ontarian law, PPE is required to be provided by the employer and worn by the employees to maintain safe working conditions. The following policies and standards related to PPE are applicable:

#### [Canada Labour Code \(R.S.C., 1995, c. L-2\)](#)

- Section 122.2 states that “Preventive measures should consist first of the elimination of hazards, then the reduction of hazards and finally, the provision of personal protective equipment, clothing, devices, or materials, all with the goal of ensuring the health and safety of the employees.”
- Section 125 (l) requires the employer to provide the prescribed safety materials, equipment, devices, and clothing and Section 126 (1) requires employees to use safety materials, equipment, devices, and clothing intended for their protection.

#### [Occupational Health and Safety Act, R. S. O. 1990](#)

- Section 25 of the Act outlines the duties of the employer requiring them to provide equipment, materials and protective devices in good condition ensuring safety measures and procedures are enforced in the workplace.
- Section 27 of the Act outlines the duties of the supervisor to ensure that protective devices, measures and procedures are conducted and that they wear equipment, protective devices or clothing required by the employer.
- Section 28 outlines the duties of the worker to work within the provisions of the Act and use or wear equipment, protective devices or clothing required by the employer.

Battery electric buses are classified as high voltage systems, and as such, require specialized tools and personal protective equipment (PPE) that may not be necessary when working on the typical 12/24 V systems found in diesel buses. Examples of additional PPE that may be required for working on high voltage systems are offered by the Transportation Learning Center. The Transportation Learning Center<sup>6</sup> provides a list of typical tools and PPE that are expected to be needed to work on BEBs which are shown in **Table 9** and **Table 10**.

<sup>5</sup> [https://www.ccohs.ca/oshanswers/hsprograms/hazard/hierarchy\\_controls.pdf](https://www.ccohs.ca/oshanswers/hsprograms/hazard/hierarchy_controls.pdf)

<sup>6</sup> [ITLC ZEB Report Final 2-11-2022.pdf \(transportcenter.org\)](#)



**Table 9. Recommended Insulated Tools**

Tool	Recommended Quantity
<b>CAT III rated digital multimeter(s) (rated up to 1000 VDC)</b>	1 for each BEB technician
<b>Insulated hand tools that follow ASTM F1505-01 and IEC 900 standards and compliance with OSHA 1910.333 (c)(2) and NFPA 70E standards (as recommended by the OEM)</b>	1 set for each BEB technician that could be working on a BEB at any given time

**Table 10. Recommended PPE for BEB Maintenance**

Tool	Recommended Quantity	Notes
<b>ASTM Class 0 insulated gloves with red label</b>	1 pair, properly sized for each technician	Insulated gloves need to be tested and replaced at specified intervals.
<b>Leather gloves to be worn over ASTM insulated gloves</b>	1 pair, properly sized for each technician	
<b>Insulated EH Rated Safety Shoes</b>	1 pair, properly sized for each technician	
<b>NRR 33 rated ear plugs</b>	Ample supply for each technician that could be working on a BEB at any given time	
<b>NRR 331 rated (overhead) earmuffs</b>	Ample supply for each technician that could be working on a BEB at any given time	Combining NRR 33 rated ear plugs with NRR 31 ear muffs can provide a NRR protection level of 36.
<b>Arc flash suits</b>	Ample supply for each technician that could be working on a BEB at any given time	
<b>Combination arc flash shield and hardhat</b>	Ample supply for each technician that could be working on a BEB at any given time	
<b>Arc flash hoods</b>	Ample supply for each BEB technician that could be working on a BEB at any given time	Arc flash shield, hardhat and hood may be procured as one integrated item depending on manufacturer and agency preference.
<b>Insulated electrical rescue hook(s) (Sheppard's Hook) sized for use on BEBs</b>	1 set for each BEB technician that could be working on a BEB at any given time (certain HV operations require a second worker to be available to extricate primary worker in an emergency)	

## 5.1.2 TRAINING PROGRAM DEVELOPMENT

Milton Transit does not currently have any in-house maintenance or training functions, but with completion of the future Milton Transit Depot Facility, Milton Transit may choose to bring these functions in-house. The town may explore providing bus operators with commercial licensing (B,C,D, and Z) as needed as well as providing in-house Corporate Health & Safety Training consisting of customer service, Accessibility for Ontarians with Disabilities Act, and health and safety topics.

Milton Transit will also consider using operations and maintenance training curriculum as established by The Ontario Public Transit Authority's (OPTA's) Zero Emission Bus (ZEB) Committee. In early 2021, OPTA recommended the establishment of the ZEB Committee in response to the need expressed by members for



the ability to learn from and share with one another as revenue and non-revenue fleets are transitioned to zero emission technology. The OPTA ZEB Committee’s mandate is to establish and maintain a forum for OPTA members to develop and share best practices, lessons learned, standard documentation, and key metrics for the implementation of zero emission vehicle technology. This forum is defined by three Workstreams:

- **WS1 - Operations and Maintenance Work Plan**
  - WS1A – ZEB Planning, Scheduling, and Operations
  - WS1B – ZEB Safety, Training, and Maintenance
  - WS1C – ZEB Performance, Monitoring, and Reporting
- **WS2 - Engineering Work Plan**
  - WS2A – ZEB Light & Heavy Duty Vehicle Requirements
  - WS2B – ZEB Infrastructure Requirements
  - WS2C – NA Technical Working Group
- **WS3 - Procurement and Vendor Engagement Work Plan**
  - WS3A – Engage Vendor Community
  - WS3B – Commercial Bus Management
  - WS3C – Paratransit EV Commercial Management
  - WS3D – Non-Revenue Vehicle Commercial Management

### 5.1.3 TRAINING CURRICULUM

BEBs contain high voltage batteries, requiring all maintenance technicians to be certified to work on high voltage (HV) systems. Milton Transit is aware of the development of zero-emissions maintenance training curriculum developed by the OPTA ZEB Committee in conjunction with other transit agencies in Ontario and anticipates implementing these training resources for Milton Transit staff when available. The OPTA ZEB Committee’s training curriculum development program aims to establish and maintain safe work conditions for bus operations and maintenance personnel serving Ontario’s fleet of BEBs.

#### 5.1.3.1 OEM TRAINING CURRICULUM

Milton Transit currently contracts with an external maintenance training provider. The Town anticipates extending the use of this program in future work plans and plans to purchase additional OEM training modules with the addition of BEBs to its fleet where the cost of training is rolled into the cost of the bus. As a part of the initial OEM training, the Town’s selected BEB OEM can be anticipated to provide training modules such as Operator Orientation, Maintenance Mechanic Training, and Towing and Emergency Responder Training.

#### 5.1.3.2 OPTA WORKSTREAM TRAINING CURRICULUM

Milton Transit will explore in-house implementation of the following courses for ZEB Safety, Training, and Maintenance as developed by OPTA’s WS1B Workplan; the detailed objectives of each course are summarized below.



### WS1B-1: ZEB Safety

- EV Systems Electrical: Arc Flash & High Voltage Work (LOTO, SOPs, etc.)
- BEB Thermal Events: Theory, Risk, and Mitigation (in collaboration with WS2 – Engineering)
- BEB EMI: Theory, Risk, and Mitigation (in collaboration with WS2 – Engineering)

### WS1B-2: ZEB Training

- Operator BEB Training Considerations & Guidelines
- Maintenance BEB Training Considerations & Guidelines
- ZEB Academia & Certifications/Endorsements (OPTA Maintenance Committee; eMobility Training Subcommittee reporting in; STO)

### WS1B-3: ZEB Maintenance

- BEB PM Program Elements
- BEB Maintenance-Specific KPIs and Comparative Analysis (Feeds WS1C: ZEB Performance Monitoring & Reporting)
- HV System Inspection Requirements (MTO NSCS11B)

## 5.1.4 SKILLS ASSESSMENT, CATEGORIZATION, AND GAP IDENTIFICATION

This section outlines workplace hierarchy, authorized responsibilities based on qualifications, skill level requirements, and training guidelines. Generally speaking, operational staff can be grouped into the following four categories:

- **Operations Support:** Staff in this category would include those who are critical to bus operations but do not directly interact with the buses.
- **Bus Operations:** Staff in this category would include operational staff who directly interact with the buses but do not perform any vehicle maintenance.
- **Bus Maintenance Support:** Staff in this category include operational staff who directly interact with the buses and are responsible for the assignment and oversight of maintenance functions.
- **Bus Maintenance:** Staff in this category include operational staff who directly interact with the buses and perform routine and unplanned maintenance functions.

Operations support staff will require minimal training that typically covers a high-level overview of the technology and its capabilities. For example, it's important for dispatchers to understand the operational range of the vehicles to avoid assigning vehicles to unsuitable routes.

Those categorized under bus operations will require more training than operations support staff given their direct interaction with the vehicles. For example, bus operators must be familiar with all dash indicator lights, the operation of doors and wheelchair access, and safety procedures.

Bus maintenance support staff include key personnel responsible for the assignment and oversight of maintenance work, both preventative and corrective, and are responsible for troubleshooting and



dispatching vehicle road calls. Milton Transit does not currently have any bus maintenance support personnel on staff. If Milton Transit determines they will bring bus maintenance activities in-house in conjunction with the zero emission fleet transition and construction of the Milton Transit Depot Facility, staff in this category will receive the same training as bus maintenance personnel as their roles include making “game time” decisions that require full familiarity with all vehicle systems and mechanical components.

Bus maintenance personnel require the most training as they have the most frequent and in-depth interaction with the vehicles. Milton Transit does not currently have any bus maintenance personnel on staff. As Milton Transit brings bus maintenance activities in-house in conjunction with the zero emission fleet transition and completion of the Milton Transit Depot Facility, staff in this category will be individually assessed on current skills and assigned to training modules as necessary, ensuring that all bus maintenance personnel receive all training required without duplicating efforts. For example, maintenance personnel who can demonstrate proficient multiplexing skills will not be assigned to multiplexing courses.

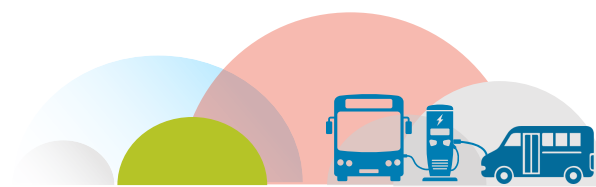
### 5.1.5 TRAINING PROGRAM IMPLEMENTATION

Milton Transit’s current technical training approach will continuously evolve, including exploration of in-house training programs. Should Milton Transit determine maintaining an outside contracted training program is most appropriate for operational needs, the agency will determine if the existing training provider is specialized to provide up-to-date information on new and existing equipment, including modern electronic and mechanical bus systems, OEM changes that impact maintenance practices, and refresher training when necessary. If the existing training provider cannot provide the necessary training for evolving ZEB vehicles and technologies, Milton Transit will contract with a more suitable training provider.

Milton Transit will take a phased approach to implement ZEB-specific training. As the number of zero emission vehicles in the fleet increases, more mechanics will complete zero emission maintenance training. For instance, if Milton Transit expects delivery of six BEBs, transition training for three mechanics to become BEB-certified fleet specialists will begin at least three months before delivery. Milton Transit expects its first non-pilot program BEB deliveries in 2025, providing ample time to identify and enroll candidates in the transition training program. This will ensure that the staff is adequately prepared when new buses arrive and aligns with the fleet replacement schedule, with a complete transition to 100% zero emissions by 2040.

### 5.1.6 FLEET APPRENTICESHIP PROGRAM

Should Milton Transit decide to implement an in-house maintenance program, the agency will explore implementation of a maintenance apprenticeship program to help develop a qualified and knowledgeable zero emissions maintenance staff. Milton Transit would sponsor the apprenticeship program with the local branch of CUPE and the Ministry of Skilled Trades (Ontario) and Industry. Applicants would apply through the Town, have completed the academic standard prescribed by the regulations for the trade or must have an Ontario Secondary School Diploma or its educational equivalent, and must successfully pass the agency’s regular employment requirements including testing.



This apprenticeship program would be designed to provide practical training for apprentices, which complements their classroom instruction<sup>7</sup>. The program aims to provide on-the-job (OTJ) training and help individuals become Certified Journey Level Heavy Duty Diesel Mechanics. To achieve this, apprentices must complete 6,000 hours of reasonably continuous employment and 720 hours of in-class instruction, which is divided into three levels/semesters, namely Basic, Intermediate, and Advanced. One of the occupational objectives under this program is to train individuals to become Coach Heavy Duty Diesel Mechanics.

### 5.1.6.1 ACADEMIC TRAINING

Any future apprenticeship program participants would be required as a condition of apprenticeship to receive and attend classroom instruction at a technical, trade, or similar school. Credit for time spent in academic training would be given in the calculation of the hours of apprenticeship served and would be applied against the period total.

As hybrid and battery electric technology becomes more prevalent in the automotive industry, automotive programs will begin to expand course curriculum to include these new systems. If Milton Transit implements an apprenticeship program for a possible future in-house maintenance program, the agency would continue to promote classes offered by local technical and trade schools and would work to establish partnerships with these institutions to build a workforce that has the technical competency to service zero emission vehicles as they are phased into the fleet.

### 5.1.7 WORKFORCE RIGHTSIZING

Should Milton Transit decide to implement an in-house maintenance program, the agency would plan to conduct an annual evaluation of its bus maintenance staffing needs. This evaluation would be based on accomplishing day-to-day maintenance functions to continuously maintain reliability and duty-cycle standards. The evaluation would also consider training hours, vacation entitlement, and absenteeism rates based on historical data. As Milton Transit transitions to a zero emissions fleet, it will re-evaluate its staffing needs on a rolling basis, based on overall fleet growth. If necessary, the agency would approve additional Apprentice Mechanic and Mechanic positions to ensure the smooth functioning of the fleet.

Due to a shortage of qualified BEB OEM training resources, Milton Transit plans to collaborate with other regional transit agencies to optimize limited OEM training resources should the agency decide to bring maintenance activities in-house. This strategy would include partnering with other agencies to maximize class sizes and sending mechanics to participate in scheduled training sessions or reserving a centrally located training location or college to host an OEM session. This coordination has received overwhelming endorsement and is a key strategic initiative through OPTA's ZEB Committee Workstreams surrounding Safety and Training. The Committee's other foundational goals include developing and sharing training programs and content, lobbying, and working with colleges to expand battery electric bus training program availability and certifications.

Milton Transit would post requisitions for open maintenance positions internally and externally at the same time with priority given to internal candidates. All Milton Transit employees would have the opportunity to apply to the Apprenticeship Program. Under an in-house maintenance program, if there are available

---

<sup>7</sup> [Skilled Trades Ontario](#)



mechanic vacancies, Milton Transit would first evaluate whether any apprentices are nearing program completion. If the position cannot be filled internally, Milton Transit would then post the vacancy externally in partnership with local trade schools.

Milton Transit offers various job positions, including Transit Supervisors and Bus Operators. As post-pandemic service levels have begun increasing, Milton is actively hiring Bus Operators. Applicants with a valid "G" driver's license, a clean driver's record, and at least one year of driving experience can apply for the job. It is not mandatory to possess a commercial driver's license for this job. Milton Transit provides training to all new bus operators through an external training provider.

Milton Transit does not have specific plans at this time to hire zero emissions-specific staff but acknowledges that specialty skills will be required to support the agency's transition to a zero emission fleet. Milton Transit will continue to monitor and assess the need for specific zero emissions staff as the fleet transition proceeds and will approve and post dedicated positions should the agency decide to bring these functions in-house.

Milton Transit currently posts job openings on the Town's website as well as on job search sites such as Indeed and in local newspapers. As the shortage of mechanics and bus operators continues, Milton Transit strives to develop more creative recruiting strategies that will address this issue. Proper marketing of the agency's Zero Emission Fleet Transition, including the potential opportunity for an advanced technical career, will be crucial to attracting, developing, and retaining the required workforce.

### 5.1.8 FUNDING OPPORTUNITIES

The expenses associated with workforce training are expected to vary, influenced by the widespread adoption of BEB's. Funding is projected to emanate from a number of sources, encompassing procurement, where training costs are incorporated into the allocated budget for vehicle or infrastructure procurement, as well as existing funding streams dedicated to training. Additionally, financial support is anticipated from federal, provincial, and local funding allocations.

While the cost of the training itself is one item to consider, the labor cost to train bus maintenance personnel is anticipated to be high. As highlighted by the International Transportation Learning Center, the following costs will be considered when budgeting for workforce training:

- Classroom training hours
- Instructor hours (instruction and prep)
- Instructor hourly wages and benefits
- Instructor costs per class
- Instructor cost per trainee
- OTJ training hours
- Mentor hours
- Mentor hourly cost
- Mentor cost per trainee
- Facilities costs
- Training materials/mock-ups/software/simulation cost

Milton Transit will continually work to identify funding sources for worker training and re-training and utilize the training funding offered through federal grants to support the agency's zero emission workforce training.





## 6 FINANCIAL PLANNING

When undertaking any major transit technology and infrastructure project, the cost to implement can be a major concern. Although capital costs are often estimated during the planning stage, the costs of operating and maintaining vehicles and infrastructure over time, as well as the costs associated with midlife rehabilitations or end of life replacements, are frequently left out of the decision-making process. These costs can become significant in the long-term and may influence future decisions.

Milton Transit’s existing diesel bus fleet has been compared to proposed BEB alternatives to identify the best value alternative for the Town to reach 100 percent conversion to BEB technologies by 2040. A high-level summary is provided below and a comprehensive breakdown of the financial analysis assumptions and results can be found in Appendix C: Budget & Financial Plan.

### 6.1 FLEET TRANSITION SCENARIOS

The financial analysis considers two scenarios for Milton Transit’s fleet transition. Each scenario evaluates the capital, operating, maintenance, and fuel/electricity costs over the 2023–2050 period. The assumptions used are detailed further below. The two scenarios evaluated reflect the following:

- **Baseline (Business as Usual) Scenario:** Reflects the scenario where no transition to BEBs occurs. All replacements of the current diesel fleet are with new diesel buses. Specialized 6m and 8m vehicles are replaced with new gas vehicles.
- **BEB Transition Scenario:** This scenario reflects the full transition of Milton Transit’s fleet to 675 kWh BEBs, and in-depot charging only as part of a phased transition beginning in 2024. Specialized 6m and 8m fleet vehicles are replaced with BEV equivalents.

### 6.2 LIFECYCLE COST ANALYSIS

The lifecycle cost analysis compares the lifecycle cost of implementing each scenario described above. Cost estimates produced in support of the active procurement of the BEBs, and associated equipment are aligned with Milton Transit’s current grant application for ICIP funding. The study period for the analysis was selected to be 27 years, from 2023–2050 as this aligns with the federal government’s current guidance on reaching net-zero emission targets.<sup>8</sup> While Milton Transit’s BEB purchase schedule ends in 2040, ending the study period in that year excludes operating cost savings for BEBs purchased in the later years of the fleet transition. For this reason, the study period is extended to 2050 to show long-term cost savings of BEBs.

A summary of the unit capital costs, annual operations and maintenance (O&M) costs, and fuel and electricity costs are shown in the table below. Annual O&M and fuel costs are based on the average diesel and BEB vehicles.

**Table 11. Capital Cost Comparison of 12M Conventional Diesel Bus and Electric Bus (2023\$)**

<sup>8</sup> [Net-zero emissions by 2050 - Canada.ca](https://www2015.statcan.gc.ca/n/pub/28-263-x/2015001/article/14861-eng.htm)





Cost Components	Baseline Scenario - Diesel	BEB Transition Scenario Battery-Electric	Variance (Per Bus Unit)
<b>Capital Expenditures</b>			
Bus Acquisition – 12M	\$915,024	\$1,909,686	\$994,662
Mid Life Refurbishment	\$120,000	\$7,000	-\$113,000
<b>Subtotal of Vehicle Costs</b>	<b>\$1,035,024</b>	<b>\$1,916,686</b>	<b>\$881,662</b>
<b>Charging Equipment*</b>			
Plug-In Depot Charger Cabinet (150 kW)	-	\$154,097	\$154,097
Plug-In Depot Charger Wall-Mounted Dispenser	-	\$25,265	\$25,265
Plug-In Depot Charger Overhead Reel Dispenser	-	\$32,158	\$32,158
<b>Subtotal of Charging Equipment Costs</b>	<b>-</b>	<b>\$211,520</b>	<b>\$211,520</b>
<b>Capital Expenditures Total</b>	<b>\$1,035,024</b>	<b>\$2,128,206</b>	<b>\$1,093,182**</b>

\*- Excludes major infrastructure and utility upgrades

\*\*-106% increase in capital investment over baseline

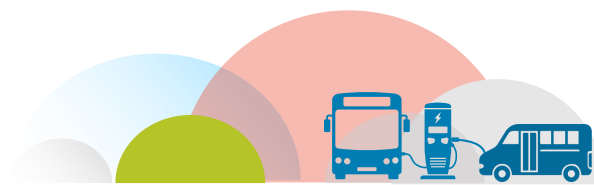
**Table 12. Annual Operating Cost Comparison of 12M Conventional Diesel Bus and Electric Bus (2023\$)**

Cost Components for Total Fleet	Diesel Bus	Battery-Electric Bus	Variance (Per Bus Unit)
<b>Operating Expenditures (per year)</b>			
Service Delivery and Administration, Training*	\$326,794	\$317,253	-\$9,541
Vehicle Maintenance + Fuel (Diesel, Gasoline, Carbon Levy)	\$99,843	\$49,620	-\$50,223
Electricity	-	\$26,502	\$26,502
Charger-Related Maintenance	-	\$5,959	\$5,959
<b>Subtotal of Service Delivery + Charging Equipment</b>	<b>\$426,637</b>	<b>\$399,334</b>	<b>-\$27,303</b>
<b>Contribution to Reserve for Asset Replacement</b>			
Vehicles (12-year life)	\$86,252	\$159,724	\$73,472
Charging Infrastructure (12-year life)	-	\$17,627	\$17,627
<b>Subtotal Contribution to Reserve for Asset Replacement</b>	<b>\$86,252</b>	<b>\$177,351</b>	<b>\$91,099</b>
<b>Total Annual Operating Cost (2023\$)</b>	<b>\$512,889</b>	<b>\$576,685</b>	<b>\$63,796</b>

\*-Based on average annual operating hours per vehicle, 2021 CUTA Statistics

## 6.2.1 CAPITAL COST ASSUMPTIONS

Capital costs include bus unit costs, mid-life rehabilitation costs, and BEB charging equipment and required electric servicing upgrades.



## 6.2.2 VEHICLE CAPITAL COSTS

Cost estimates were based on recent experience with other transit agencies and include infrastructure required for the BEB scenarios modelled. **Table 13** contains the capital cost assumptions used in the lifecycle cost analysis.

**Table 13. Capital Unit Cost Assumptions, 2023\$**

Capital Assumptions	
Diesel Bus Cost	\$915,024
Battery Electric Bus Cost (675 kWh)	\$1,909,686
Repowering Cost (Pilot Bus Conversion)	\$600,000
6m Specialized Transit (ICE)	\$218,473
6m Specialized Transit (BEB)	\$393,319
8m Specialized Transit (ICE)	\$258,888
8m Specialized Transit (BEB)	\$462,843
Midlife Rehabilitation Cost – Diesel	\$120,300
Midlife Rehabilitation Cost – BEB	\$7,000
Plug-In Depot Charger Cabinet (150 kW)	\$154,097
Plug-In Depot Charger Wall-Mounted Dispenser	\$25,265
Plug-In Depot Charger Overhead Reel Dispenser	\$32,158

## 6.2.3 INFRASTRUCTURE CAPITAL COSTS

In addition to the unit capital costs above, infrastructure phasing costs at the Milton Transit Depot Facility are shown in **Table 14**. Lump sum phasing costs include budgetary pricing provided by electrical infrastructure OEMs for unit substations, and typical unit costs for other civil and electrical work (conduits, grounding, patching), and other anticipated construction expenses. The per-phase costs also factor in a 4% engineering design and a 30% contingency based on concept plan details.

**Table 14. Infrastructure Phasing Assumptions**

Phase	Cost	Year	Key Equipment
Phase 1	\$7,472,500	2025	Unit substation (#1), initial deployment of chargers as shown in the phasing plan and concept figures.
Phase 2A	\$2,827,400	2026	Expansion of DCFC and Level 2 charging infrastructure.
Phase 2B	\$3,748,000	2029	Expansion of DCFC and Level 2 charging infrastructure.
Phase 3	\$17,785,500	2031	Unit substation (#2), ultimate deployment of chargers as shown in the phasing plan and concept figures.

**Table 15** displays a comparison between the capital costs under each scenario. Implementing a full transition to BEBs will result in an additional \$63.1 million in capital costs relative to the Baseline scenario. This is largely driven by the higher capital cost of 675 kWh buses, and the additional electrification infrastructure required.



**Table 15. Capital Cost Comparison, Millions of 2023\$, 2023-2050**

	Baseline	BEB	Variance
<b>Diesel – Replacement</b>	\$42.1	\$6.4	-\$35.7
<b>Diesel Replacement Quantity</b>	45	7	
<b>Diesel – Growth</b>	\$65.9	\$11.0	-\$54.9
Diesel Growth Quantity	72	12	
<b>BEB – Replacement</b>	-	\$72.6	\$72.6
<b>BEB Replacement Quantity</b>	-	38	
<b>BEB – Growth</b>	-	\$114.6	\$114.6
BEB Growth Quantity	-	60	
<b>8m Specialized ICE – Replacement</b>	\$6.2	\$0.8	-\$5.4
<b>8m ICE Replacement Quantity</b>	24	3	
<b>8m Specialized BEB – Replacement</b>	-	\$9.7	\$9.7
8m BEB Replacement Quantity	-	21	
<b>6m Specialized ICE – Replacement</b>	\$11.6	\$0.7	-\$10.9
6m ICE Replacement Quantity	53	3	
<b>6m Specialized BEB – Replacement</b>	-	\$19.7	\$19.7
6m BEB Replacement Quantity	-	50	
<b>6m Specialized ICE – Growth</b>	\$2.4	\$0.9	-\$1.5
6m ICE Growth Quantity	11	4	
<b>6m Specialized BEB – Growth</b>	-	\$2.8	\$2.8
6m BEB Replacement Quantity	-	7	
<b>Total Fleet Purchases</b>	<b>\$128.2</b>	<b>\$239.0</b>	<b>\$110.8</b>
<b>Diesel Midlife Rehabilitation</b>	\$81.4	\$2.3	-\$79.2
<b>BEB Midlife Rehabilitation</b>	-	\$0.5	\$0.5
<b>Additional Infrastructure</b>	-	\$31.8	\$31.8
<b>Total Fleet Lifecycle Capital Costs</b>	<b>\$209.6</b>	<b>\$273.6</b>	<b>\$64.0</b>

## 6.3 OPERATING & MAINTENANCE COST ASSUMPTIONS

Ongoing fueling and maintenance costs for Milton Transit’s existing transit vehicles and modelled BEB replacements are part of this analysis.

### 6.3.1 OPERATING COST ASSUMPTIONS

Operations and maintenance (O&M) costs associated with the transition to BEBs considered the regular expenses required to maintain the Milton Transit conventional diesel fleet, as well as any incremental maintenance costs for new BEB infrastructure. O&M costs for the buses were calculated using historical Milton Transit maintenance cost data. Annualized O&M costs for BEB charging equipment were estimated from a published service level agreement of representative in-depot chargers. **Table 16** contains the key O&M assumptions in the analysis; a more detailed discussion regarding these estimates is included in **Appendix C: Budget & Financial Plan**.



**Table 16. Fixed Route Fleet O&M Unit Cost Assumptions, 2023\$**

Conventional Fleet Operating Assumptions	Diesel	BEB
Operating Costs (\$/hr)	\$98.59	\$98.59
Fixed Route Bus Maintenance Cost (\$/km) <sup>9</sup>	\$0.64	\$0.58
Specialized Bus Maintenance Cost (\$/km)	\$0.61	\$0.55
BEB Maintenance Cost Efficiency Factor	-	10%
Charger Efficiency	-	95%
Charger Maintenance Cost (\$/year)	-	\$5,959
Average Useful Life of New Bus	12	12
Bus Fuel Efficiency (L/100 km)	46.1	-
Diesel Heater Efficiency (L/km)	-	0.034
Spare Bus Ratio (Peak Fleet/Total Fleet)	6%	6%
Fixed Route Transfer to Reserve (\$/year)	\$76,252	\$159,140

**Table 17** contains the unit costs and key operations assumptions of the specialized transit fleet. Based on industry standards of expected useful life for cutaway vehicles, 6m and 8m BEBs are expected to have a useful life of about 8 years, compared to 7 for conventional ICE buses.

**Table 17. Specialized Fleet O&M Unit Cost Assumptions**

Specialized Fleet Operating Assumptions	Diesel	BEB
Specialized Bus Maintenance Cost (\$/km)	\$0.61	\$0.55
BEB Maintenance Cost Efficiency Factor	-	10%
Average Useful Life of New Bus	7	8
Bus Fuel Efficiency (L/100 km)	39.1	-
8m Specialized Transfer to Reserve (\$/year)	\$36,984	\$57,855
6m Specialized Transfer to Reserve (\$/year)	\$31,210	\$49,165
Daily Energy Usage per 6m Vehicles (kWh)		76.9
Daily Energy Usage per 8m Vehicles (kWh)		88.6
8m Average Daily Kilometres Driven	177	177
6m Average Daily Kilometres Driven	147	147
8m Average Daily Hours Utilized	10	10
6m Average Daily Hours Utilized	10	10

**Table 18** displays the comparison of O&M lifecycle costs between the different scenarios. The costs are comparable under both scenarios for operations and maintenance costs. Notable differences include the incremental maintenance costs between the Baseline Scenario and BEB Scenario due to additional

<sup>9</sup> Note that while \$/km maintenance costs are lower for BEBs, these are offset by the deadhead kilometres driven to facilitate bus swaps due to their shorter range relative to diesel equivalents.



infrastructure. In addition, annual transfers to reserve for lifecycle replacement costs are higher under the BEB scenario.

**Table 18. O&M Cost Comparison, Millions of 2023\$, 2023-2050**

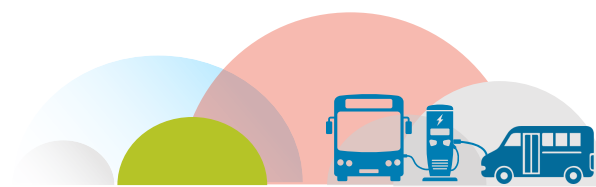
	Baseline	BEB	Variance
<b>Diesel O&amp;M</b>	\$414.2	\$121.8	-\$292.4
<b>BEB O&amp;M</b>	-	\$286.7	\$286.7
<b>Diesel Bus – Transfer to Reserve</b>	\$89.0	-	-\$89.0
<b>BEB – Transfer to Reserve</b>	-	\$153.7	\$153.7
<b>8m Specialized Gas Transfer to Reserve</b>	\$5.1	-	-\$5.1
<b>8m Specialized BEB Transfer to Reserve</b>	-	\$8.8	\$8.8
<b>6m Specialized Gas Transfer to Reserve</b>	\$11.3	-	-\$11.3
<b>6m Specialized BEB Transfer to Reserve</b>	-	\$20.3	\$20.3
<b>Electrical Infrastructure Transfer to Reserve</b>	-	\$8.3	\$8.3
<b>Related Infrastructure O&amp;M Costs</b>	-	\$1.5	\$1.5
<b>Total Fleet Lifecycle O&amp;M Costs</b>	<b>\$519.7</b>	<b>\$601.2</b>	<b>\$81.4</b>

### 6.3.2 FUEL & ELECTRICITY COSTS

Fuel and electricity costs associated with the transition include the propulsion of diesel and BEBs, and diesel fuel to operate electric heaters on board BEBs. Diesel fuel costs were estimated using wholesale diesel fuel prices per litre for Milton, and escalated to include federal and provincial HST, as well as the federal carbon tax. The average price of diesel fuel per litre was applied to total diesel consumption. Estimated electricity costs are based on Milton Hydro’s average per kilowatt-hour and per kilowatt charges, combined with 2023 year to date Ontario electricity prices. These charges were applied to the total kilowatt-hours and kilowatts to be consumed, respectively. **Table 19** provides the assumptions used for the fuel and electricity cost comparison.

**Table 19. Fuel and Electricity Cost Assumptions, 2023\$**

Fuel and Electricity Cost Assumptions	
<b>Diesel Price (2023\$/L)</b>	\$1.44
<b>Gasoline Price (2023\$/L)</b>	\$1.41
<b>Carbon Levy on Diesel (2023\$/L)</b>	\$0.17
<b>Carbon Levy on Gasoline (2023\$/L)</b>	\$0.14
<b>Electricity Consumption Price (2023\$/kWh)</b>	\$0.20
<b>Electricity Demand Price (2023\$/kW)</b>	\$11.67
<b>Charger Efficiency</b>	95%



In the Baseline Scenario fuel costs are more expensive due to the increasing price of diesel, driven in part by escalating carbon taxes, and costs \$22.7 million more than the BEB Scenario. **Table 20** includes the fuel and electricity lifecycle cost comparison.

**Table 20. Fuel and Electricity Lifecycle Cost Comparison, Millions of 2023\$, 2023-2050**

	Baseline	BEB	Variance
<b>Diesel Costs</b>	\$49.5	\$16.6	-\$32.9
<b>Electricity Costs</b>	-	\$23.8	\$23.8
<b>Carbon Levy Costs</b>	\$19.4	\$5.7	-\$13.6
<b>Total Fleet Lifecycle Propulsion Costs</b>	<b>\$68.9</b>	<b>\$46.2</b>	<b>-\$22.7</b>

### 6.3.3 OVERALL LIFECYCLE COST COMPARISON

**Table 21** below shows the overall lifecycle cost comparison between the Base and BEB Scenarios. It is anticipated that the cost of transitioning to BEBs will be \$37.1 million over the Baseline, in 2023-dollar terms. Additionally, the analysis assumes that capital costs will not be offset by grant or incentive funding. Including additional funding sources, such as ICIP or ZETF, may affect the results of the analysis. However, since these funds have not been applied for or secured by Milton Transit, they are not included in this analysis. Please note that the transfer to reserve costs is not included in the totals for either scenario, as this would substantially overstate the projected costs.

**Table 21. Overall Lifecycle Cost Comparison, Millions of 2023\$, 2023-2050<sup>10</sup>**

2023\$	Baseline Scenario	BEB Transition Scenario	Variance
<b>Buses</b>	\$108.0	\$204.5	\$96.6
<b>Midlife Rehabilitation</b>	\$81.4	\$2.8	-\$78.7
<b>Specialized Transit</b>	\$20.2	\$34.4	\$14.2
<b>Related Infrastructure</b>	-	\$31.8	\$31.8
<b>Life Cycle Capital Costs, Total</b>	<b>\$209.6</b>	<b>\$273.6</b>	<b>\$64.0</b>
<b>Operations &amp; Maintenance</b>	\$398.4	\$393.0	-\$5.5
<b>Propulsion</b>	\$55.7	\$41.1	-\$14.6
<b>Related Infrastructure O&amp;M</b>	-	\$1.5	\$1.5
<b>Life Cycle O&amp;M, Fixed Route</b>	<b>\$454.1</b>	<b>\$435.6</b>	<b>-\$18.5</b>
<b>Operations &amp; Maintenance</b>	\$15.8	\$15.5	-\$0.2
<b>Propulsion</b>	\$13.2	\$5.1	-\$8.1
<b>Life Cycle O&amp;M, Specialized Transit</b>	<b>\$29.0</b>	<b>\$20.7</b>	<b>-\$8.3</b>
<b>Total Fleet Lifecycle Costs</b>	<b>\$692.7</b>	<b>\$729.8</b>	<b>\$37.1</b>

<sup>10</sup>Note that **Table 21** does not include lifecycle replacement transfers to reserve, as the capital costs are included. To determine lifecycle costs over the 2023-2050 study period, replacement transfers are not included, to avoid double counting. Over the study period, replacement transfers for the conventional fleet are expected to be \$153.7 million, \$8.3 million for the infrastructure, and \$29.1 million for the specialized fleet.



## 6.4 FUNDING PLAN

There are several external financing opportunities Milton Transit will consider in order to secure funding for the zero emission fleet transition. The two primary external funding sources are the Investing in Canada Infrastructure Program (ICIP) and the Zero Emission Transit Fund (ZETF).

The ICIP program is administered by Infrastructure Canada and has invested \$131 billion in over 85,000 projects. This program has already funded several other municipalities' transit fleet buses, including conventional transit and other mobility services. The federal government will invest up to 40% for most municipal public transit costs, though this may increase to 50% for rehabilitation projects. Funding provided by Infrastructure Canada is divided among the provinces who distribute funding by municipality. It is noted that the Town was successful in retaining approximately \$7.2 million in ICIP funds for the development of a Transit Garage Facility.

The ZETF is administered by Infrastructure Canada, and targets projects that enable or implement transit fleet electrification. The ZETF offers flexible financing solutions, including grants and loans through the Canada Infrastructure Bank (CIB) to applicants. ZETF funding decisions are determined by project viability, estimated operational savings, and estimated GHG emission reduction. Approximately \$2.75 billion in funding is earmarked for the ZETF program to support the numerous municipal transit agencies that may apply for that funding.

Funding from either program may be used to offset planning, capital, and operating costs associated with transitioning diesel fleets to BEBs or alternative fuel technologies. As this funding has not been secured by Milton Transit, it is not included in this analysis.



## 7 ENVIRONMENTAL BENEFITS

Greenhouse gas (GHG) emissions reduction is a significant benefit of transitioning from a diesel fleet to BEBs. This section helps quantify the impacts that Milton Transit’s conversion to BEBs may have on GHG emissions relative to the baseline diesel scenario; results do not consider GHG emissions associated with fabrication and construction of new BEB infrastructure or with resource extraction for the vehicles, etc.

### 7.1 ASSUMPTIONS & METHODOLOGY

The analysis quantified GHG impacts based on estimates of diesel fuel and electricity usage by transit buses over the 2023-2050 period. The following assumptions were used to quantify emissions based on litres of fuel and kWh of electricity consumed. Milton Transit’s current fleet consumes biodiesel fuel and the emission factor selected reflects this.

The emission rate for diesel fuel is 2.681 kilograms (kgs) of carbon dioxide (CO<sub>2</sub>) per litre of fuel. The emission rate for gasoline fuel is 2.28 kgs of CO<sub>2</sub> per litre of fuel. These values were obtained from the Canadian National Inventory Report, 2023. The emission rate was multiplied by the annual litres of fuel consumed to calculate the annual kgs of CO<sub>2</sub> emitted. To quantify the impact of electricity usage on GHG emissions, the total kWh of electricity used per year was multiplied by the corresponding Electricity Emission Intensity factor for Ontario from 2023 to 2050. This factor represents the kg of CO<sub>2</sub> per kWh based on the average electricity grid mix for the province. The intensity factor declines over time due to anticipated introduction of new renewable power generation sources. The Electricity Emission Intensity Factor was obtained from the Average Grid Electricity Emission Intensities table in the ZETF GHG+ Guidance Modules, Annex C.

### 7.2 GHG EMISSION REDUCTION IMPACTS

Based on the assumptions above, the GHG emissions from BEB operations of Milton Transit’s fleet are summarized in **Table 22**. Over the study period, BEBs will reduce emissions by approximately 76,900 tonnes. This translates to approximately 185 tonnes of CO<sub>2</sub> saved per year, per bus.

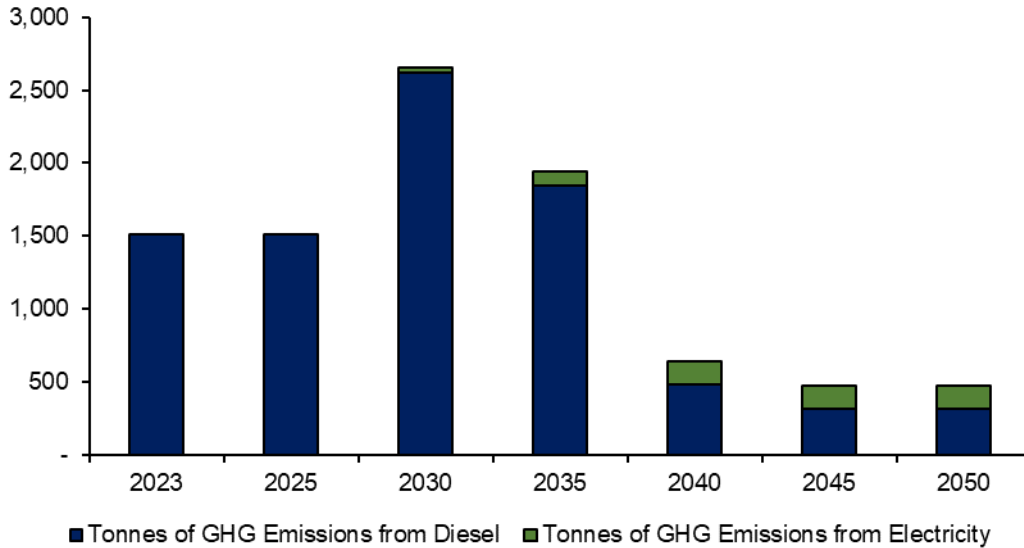
**Table 22. Total GHG Emissions (CO<sub>2</sub> in Tonnes)**

	2025	2030	2040	Total
<b>Diesel</b>	2,168	4,134	5,156	120,466
<b>BEB</b>	-	-	-	-
<b>Total, Baseline Scenario</b>	<b>2,168</b>	<b>4,134</b>	<b>5,156</b>	<b>120,466</b>
<b>Diesel</b>	2,168	3,144	487	40,374
<b>BEB</b>	-	40	174	3,131
<b>Total, BEB Scenario</b>	<b>2,168</b>	<b>3,184</b>	<b>662</b>	<b>43,505</b>

There is a substantial decline from approximately 2,200 tonnes of GHGs per year to just below 700 tonnes per year in the BEB Scenario (**Figure 10**). Emissions remaining after the complete transition of the fleet to BEBs is due to diesel auxiliary heating on board BEBs.

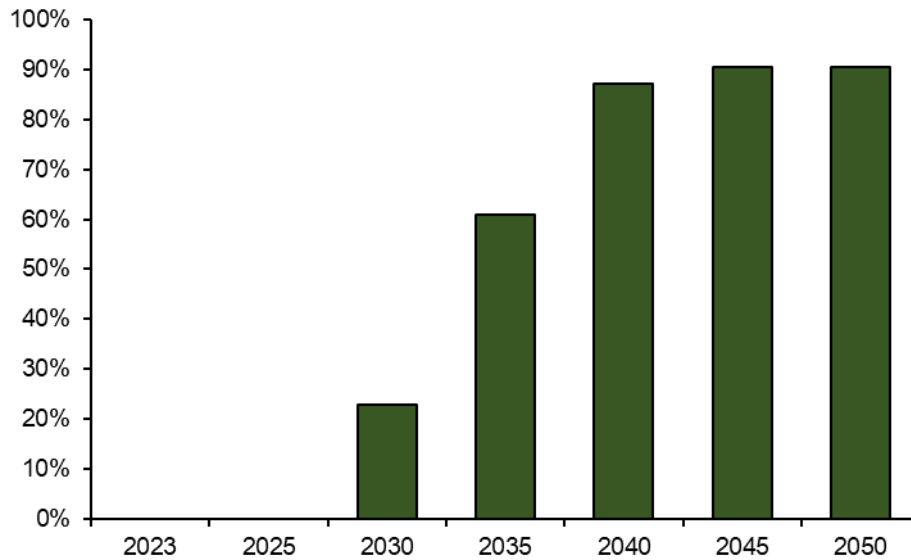






**Figure 10. Annual GHG Emissions (CO<sub>2</sub> in Tonnes), BEB Scenario**

The cumulative percent reduction in GHG emissions is shown in **Figure 11**. The annual emissions reduced grows substantially over time as the diesel fleet is converted to BEBs. By the end of the transition to BEBs, emissions are reduced by approximately 90%.



**Figure 11. Percentage GHG Reductions from Baseline in BEB Scenario**



## 8 PROJECT RISKS & MITIGATION

New technology introduces a host of potential risks associated with transitioning Milton Transit’s fleet to a new fuel source. The table below highlights potential areas of risk associated with implementation and operation of BEBs into Milton Transit’s fleet, accompanied by the response or countermeasure Milton Transit will take for each identified risk. It should be noted that risk exposure is subjective by nature and the plan’s risk exposure will continuously evolve throughout the transition.

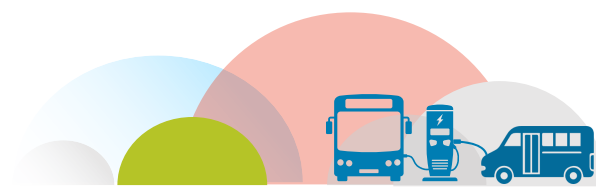
Risk	Risk Description	Risk Response
<b>Infrastructure Transition</b>	As BEBs are introduced to the fleet, it is essential that the necessary infrastructure is in place to enable their integration into the service. Coordination with third parties, such as local utilities and infrastructure manufacturers, can often result in lengthy timeframes and disruptions to current operations.	Initiate planning for infrastructure and ensure construction considerations are made while maintaining current operations. See that infrastructure upgrades are completed at least six months in advance of vehicles arriving. Following infrastructure installation, it is critical to conduct comprehensive testing and commissioning before placing vehicles and infrastructure into active service.
<b>Internal Resource Availability to Support Implementation</b>	The implementation of BEBs will require program management and operational support and may result in resource limitations, additional costs, and delays.	Identify key personnel for the management of procuring the vehicles and infrastructure upgrades as a coordinated program. See that existing resources are supplemented by hiring new roles to address gaps that are been identified. Engage consultants as necessary to offer support during project delivery to support the procurement process, construction, delivery and commissioning. Continue to leverage the Metrolinx TPI Group Purchasing program for procurement and contract administration for BEB and required charging infrastructure.
<b>Service Planning and Scheduling</b>	The BEB fleet will introduce new variables and processes into service planning and scheduling. Adjusting to these new requirements may take additional time and resources, which could result in an increased cost of service delivery and potential delays in implementation. It is important for service planning and scheduling to be flexible to the changes brought about by the new fleet to ensure smooth and efficient operations.	Initiate service planning adjustments at an early stage to gain insights into the attributes and operational limitations of BEBs using data from the Transition Plan. Ensure staff to identify necessary information and tools, assist them in acquiring additional capabilities, and support optimization of schedules with BEBs to maximize fleet utilization and minimize operating costs.



Risk	Risk Description	Risk Response
<b>Revenue Operations Assumptions</b>	<p>The modelling forecasts the fleet size required to maintain current operations considering operator hours and associated operating costs. However, the underlying assumptions may not consider the full range of operations which may underestimate operational costs.</p>	<p>Initiate the adjustment of service planning practices to align with the characteristics and operational constraints of BEBs using insights from the Transition Plan. This approach aims to minimize the chance of adverse impacts. Additionally, start early and engage in a constructive dialogue with unions to mitigate the impact of any deviations from expected models. The use of on-board AVL / Electric Bus Telematics Software will be critical in creating critical alerts around battery state of charge and operating metrics.</p>
<b>Supply Chain Disruptions</b>	<p>The ongoing global shortage of electrical subcomponents, replacement parts, and heightened production demand due to the increased funding available for zero-emissions bus fleets may result in shortages of parts and tooling which would increase costs and delay procurement. Delays in vehicle procurement and delivery would also result in increased maintenance requirements for the current diesel fleets.</p>	<p>Consider supply chain disruptions, as they are applicable to both buses and fixed electrical infrastructure. Plan for adequate lead time to account for potential manufacturing and delivery delays. Ensure that enough local spare parts are maintained either through contracts or storage at the transit facility. Lists of types and quantities of critical spare parts should be provided by both vehicle and charging system suppliers. Strategies to address some of these challenges have been built into the Metrolinx TPI procurement contract (e.g. late delivery penalties, parts availability, etc.).</p>
<b>Resiliency</b>	<p>Utility blackouts, primary and secondary infrastructure failures, as well as natural disasters or extreme weather events, have the potential to significantly disrupt operations.</p>	<p>Assess the impact and frequency of power outages to evaluate mitigation options that will meet the organization’s risk tolerance. Consider the options provided in the facilities report to determine what level of resiliency is required. Having a plan to replace major critical electrical components with long lead times, such as transformers, should be evaluated.</p>



Risk	Risk Description	Risk Response
<b>Insufficient Grid Capacity</b>	The planned fleet will require significant power demand which may not be available with current infrastructure and could require additional costs to install new transmission lines or substations	Begin constructive engagement with local utilities to ensure necessary infrastructure upgrades are in place in time to support the charging equipment in the early stages. Engagement should be done with the utility as soon as a site is selected for the new bus garage to discuss capacity required and see if the utility will be able to provide the power required. Upgrades will also need to consider impacts from other facility related electrification such using electric heat pumps for HVAC.
<b>Technology Interoperability</b>	Potential incompatibility between buses and chargers from different manufacturers may be discovered during testing and commissioning which would result in additional costs and delays.	Thoroughly inquire and assess the compatibility of the equipment to be purchased during the procurement phase. Ensure contracts include testing and commissioning of vehicles with any equipment that is expected to be used. Plan would be to standardize on infrastructure provider and develop Service Level Agreement.
<b>Technology Obsolescence</b>	The technology for EVs is quickly evolving and older generation vehicles and chargers may not be compatible with newer ones. These changes can be driven by updates to charging standards, advancements in battery technology, or changes in design principles. As a result, retrofitting older models with the latest technology	Prior to the procurement of additional vehicles and infrastructure, regular and periodic market scans of the current state of the industry are recommended. Vehicle and charging manufacturers should be expected to maintain spare components for the expected lifespan of vehicles. Additionally, a sufficient supply of spare components should be purchased to ensure equipment is able to be kept serviceable. Leverage Metrolinx TPI Group Purchasing contracts to assist with contract administration as well as obsolescence and parts availability throughout the life of the contract. Evaluate alternative delivery options to lease / finance infrastructure through the utility or another 3 <sup>rd</sup> party.



Risk	Risk Description	Risk Response
<b>Software Issues</b>	<p>The smart charging software available in modern chargers is subject to bugs and disruptions which would negatively impact operations.</p>	<p>Ensure thorough testing and commissioning are carried out after installation of new infrastructure servicing BEBs and that timely support is available for software that is essential to operations. Leverage Metrolinx TPI Group Purchasing contracts to assist with contract administration and language surrounding obsolescence, reliability and parts availability throughout the life of the contract. Utilize charge-management software to pro-actively alert any charging faults, etc. Review option to have the utility manage charging infrastructure under a service contract.</p>
<b>Software Adoption</b>	<p>Delays or failure to adopt necessary software tools for electrification, such as smart charging, dispatch, and control, planning and scheduling, depot management, and fleet telematics, may cause implementation delays for electrification.</p>	<p>Before procuring new infrastructure for BEBs, conduct a comprehensive assessment of software and data needs. Once installed, thoroughly test and commission the new infrastructure. Leverage Metrolinx to share ideas and best practices around software deployment. This should also consider how it may apply to a broader fleet transition like Municipal Zero Emission Fleet Plans and Infrastructure Planning.</p>
<b>Known-Unknowns</b>	<p>The Town has identified a number of anticipated costs to be incurred as a result of the transition to BEBs, but the magnitude of these costs is unknown and/or unable to be predicted with any degree of accuracy. These costs include the cost of training for operations and maintenance staff, potential increases in facility insurance premiums to store BEBs indoors relative to storage of diesel and gasoline vehicles, and the incidental costs associated with implementation of en-route charging infrastructure (including land ownership, right-of-way, utility upgrades, etc.)</p> <p>The Town has also identified the potential labor constraints with maintenance contractors and service providers.</p>	



## APPENDIX A: ENERGY MODELLING ANALYSIS

### FIXED-ROUTE SERVICE

The service data used was based on GTFS data for service in 2023, which is representative of current (post-COVID) service conditions. Five fixed-route service BEB scenarios were modelled: baseline, depot charging only with 525 kWh batteries, depot charging only with 675 kWh batteries, and depot and en-route charging with 525 kWh batteries. All scenarios are detailed below following a discussion of key assumptions.

### KEY ASSUMPTIONS

To develop a model relevant for Milton Transit’s fleet and operations, a set of assumptions and variables were identified and displayed in **Table 23**. It is noted that the assumptions regarding vehicle Original Equipment Manufacturer (OEM) attributes represent a typical, commercially available BEB model. Subsequent procurements following this analysis may result in vehicle OEM specifications which differ from these assumptions, which may impact the results of this analysis. Additional energy consumption modelling based on the selected OEM should be conducted to confirm any changes in energy and infrastructure requirements.

**Table 23. BEB Simulation Assumptions**

Variable	Input
<b>Service Data</b>	December 2022 – January 2023
<b>Battery Capacity</b>	525 kWh (Existing vehicle battery size) 675 kWh (Expected future vehicle battery size)
<b>End-of-Life Battery State of Health</b>	80% (max battery degradation)
<b>Energy Reserve</b>	20% state of charge (SOC)
<b>Heating</b>	Diesel Auxiliary Heat
<b>Ambient Temperature</b>	-22C (Cold weather, 10 <sup>th</sup> percentile) +27C (Hot weather, 90 <sup>th</sup> percentile)
<b>Passenger Capacity</b>	100% seated capacity
<b>Depot Charger Power</b>	150 kW @ 95% Efficiency
<b>En-route Charger Power</b>	450 kW (Vehicle Limited) @ 95% Efficiency

### BASELINE SCENARIO

The first modelled scenario assumes depot charging is allowed all day with no modifications to block schedules. Buses are reused if a vehicle has a minimum state-of-charge (SOC) of 60% or higher. In this scenario, if a short block is completed and the bus has at least 60% SOC, then the vehicle is used again in the same day to start another block that it can complete. This gives an indication of how feasible the blocks will be based on how Milton currently operates. The results of the baseline scenario indicate that vehicles were not able to complete several of the blocks, so this scenario was discounted as it is not a viable option.

### DEPOT CHARGING ONLY SCENARIOS

These scenarios evaluated a fleet of either 525kWh or 675kWh BEBs with on-board diesel auxiliary heaters that would utilize plug-in depot chargers. It was assumed that buses would be swapped out part way



through the block with a fully charged vehicle when the first vehicle reaches 20% SOC. By swapping the buses, they would be scheduled to run shorter blocks that align with the capabilities of the BEBs.

The model also assumes that when swaps occur, the bus that would normally stay in service would return to the depot, and another bus and operator would drive from the depot to take its place. This has impacts both on fleet size required (peak vehicle requirement) as well as operational costs due to the increased amount of deadhead miles incurred (non-revenue hours and kilometres between the depot and the first/last stop).

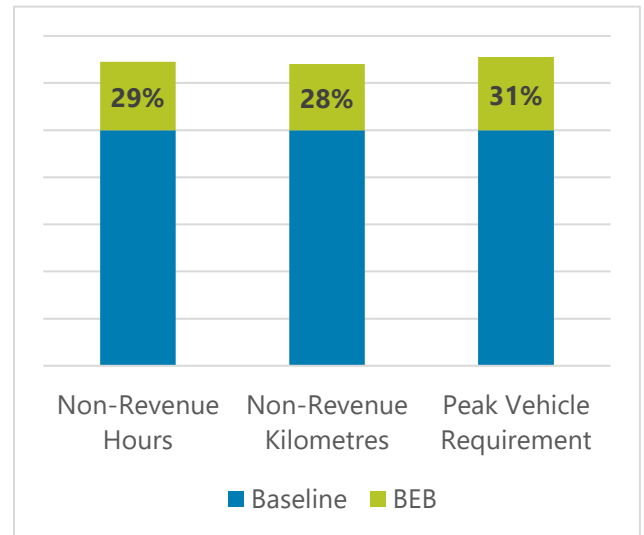
### MODEL RESULTS: 525 KWH BATTERY CAPACITY

A review is provided below that details the main components of the transit service and operations likely to change when transitioning to a 525kWh BEB fleet using only depot charging. **Figure 12** shows an estimate of the increase in non-revenue hours and kilometres as well as the estimated number of vehicles required to continue the current transit service.

- Revenue hours and kilometres remain the same
- Non-revenue hours: **29% increase**
- Non-revenue kilometres: **28% increase**
- Peak Vehicle Requirement: **31% increase**
- At least 3 depot chargers will be required:
  - (3) 150 kW plug-in chargers
- (9) 525kWh BEBs can be deployed before an increase in fleet size is required

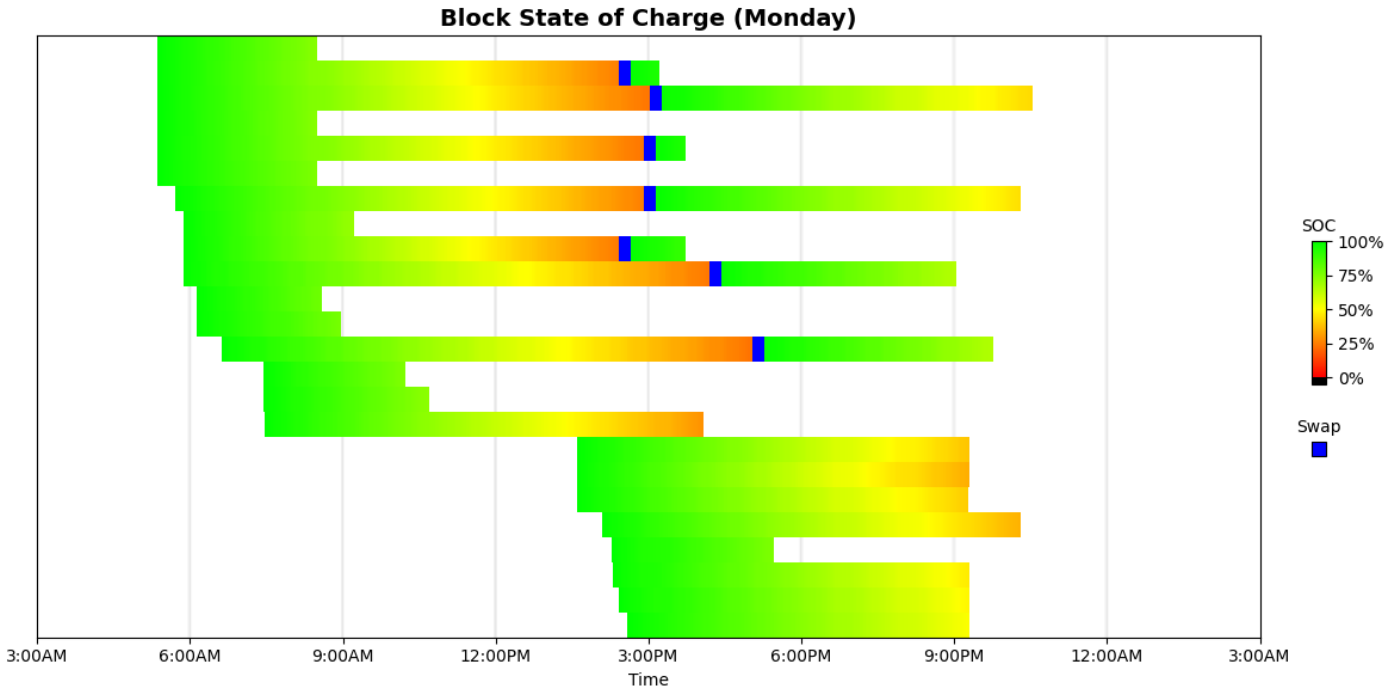
The vehicle battery states of charge on each block during weekday service are shown in **Figure 13**. Weekend service was also modelled, but fleet and charging requirements are driven by weekday service which illustrates the most demanding operations for Milton Transit.

Each block is represented by a line on the chart with the color of the line corresponding to the state of charge of the vehicle. The color changes from green to yellow to red to black as the state of charge drops from 100 to 0 percent. Bus swaps (shown in blue) are introduced only between trips to minimize service impacts. Bus swaps are also inserted in locations shown in blue to guarantee the minimum SOC does not dip below the required 20 percent reserve capacity, including the energy needed to return the vehicle to the depot when a swap is needed. Whenever a vehicle is swapped out, it is replaced with a BEB that has a fully charged battery. Swapping buses is only helpful when the bus either stays near the depot all day or returns within a close distance to the depot at multiple points throughout the day. If a block is scheduled to travel a long distance away from the depot, then there is no convenient opportunity for a swap.



**Figure 12. 525kWh BEB Depot Charging Only Model Outputs**





**Figure 13. 525kWh BEB Depot Charging Only - Weekday Service Block SOC Heatmap**

The modelling reveals which existing service blocks are feasible without the need for en-route charging or a bus swap to complete service. **Table 24** shows which service blocks are feasible with 525 kWh buses and infeasible, respectively. A total of 17 blocks (71%) can be replaced with BEBs at a 1-to-1 ratio without the need for en-route charging. The remaining 7 blocks (29%) would require either en-route charging or a bus swap to complete service.

**Table 24. Summary of Feasible Blocks without Swap for 525 kWh BEB**

Feasible with 525 kWh Bus			Infeasible with 525 kWh Bus
1225529	1225534	1225574	1225553
1225533	1225569	1225514	1225541
1225540	1225519	1225547	1225575
1225544	1225566		1225567
1225556	1225579		1225524
1225557	1225580		1225509
1225592	1225597		1225550

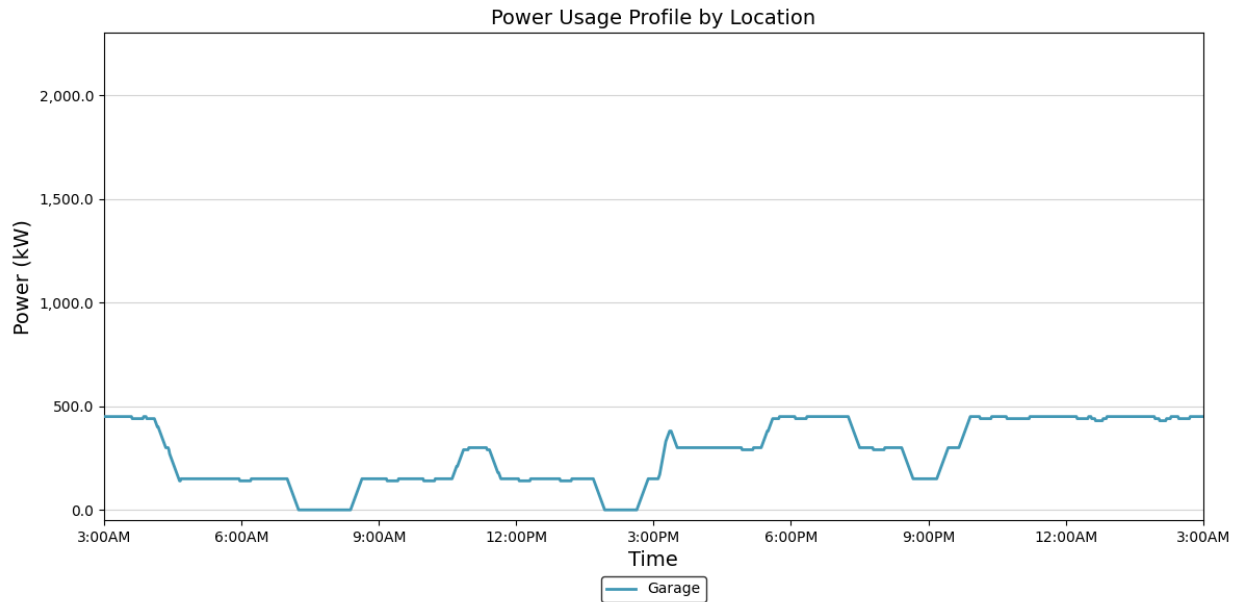
### Power Requirements

**Figure 14** shows the daily power demand profile for 525kWh BEBs at the depot facility if Milton Transit elects to continue with depot charging only. The highest power demand occurs overnight, peaking at 450 kW, when buses return to the depot and are plugged in. There are two peaks during the day, one between





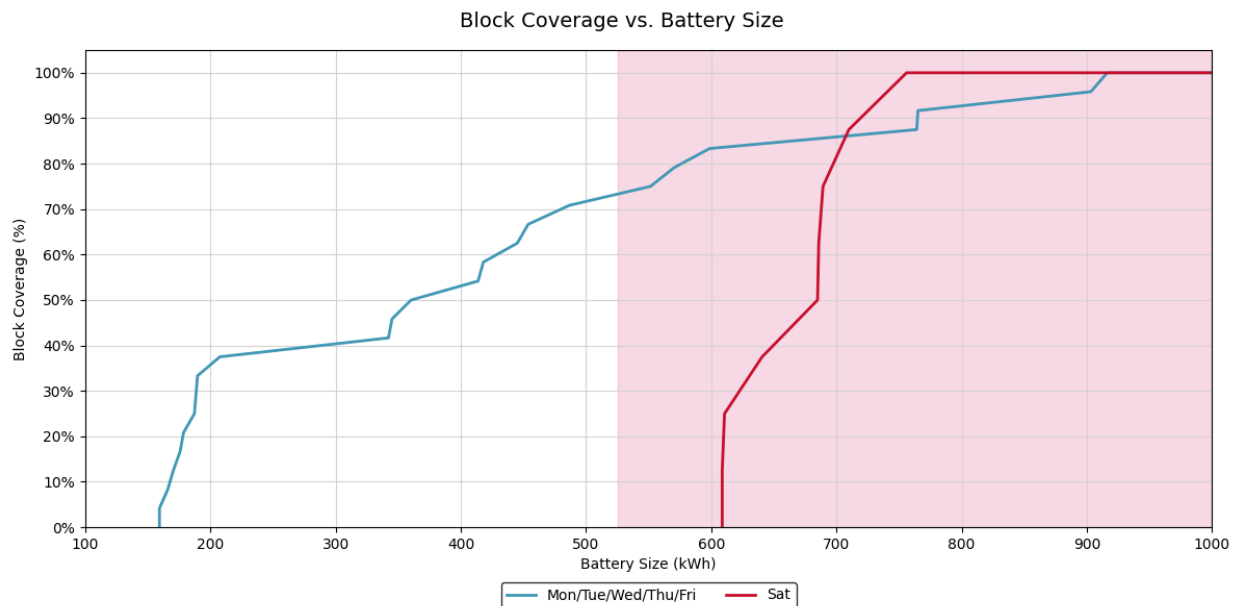
5pm to 7pm and another between 10pm to 4am. Between 5am to 3pm, the demand is relatively low.



**Figure 14. 525kWh BEB Depot Charging Only Maximum Daily Power Profile at Depot Facility**

### Vehicle Battery Capacities

**Figure 15** shows what the percentage of Milton Transit’s service becomes feasible without en-route charging by battery size. With 525 kWh buses, 71% of weekday services blocks can be replaced one-to-one without en-route charging. Increasing to 675 kWh, feasibility increases to 83% and a bus battery capacity would need to be at least 1 MW for 100% of service blocks to be feasible.



**Figure 15. Block Feasibility by Required Vehicle Battery Size**

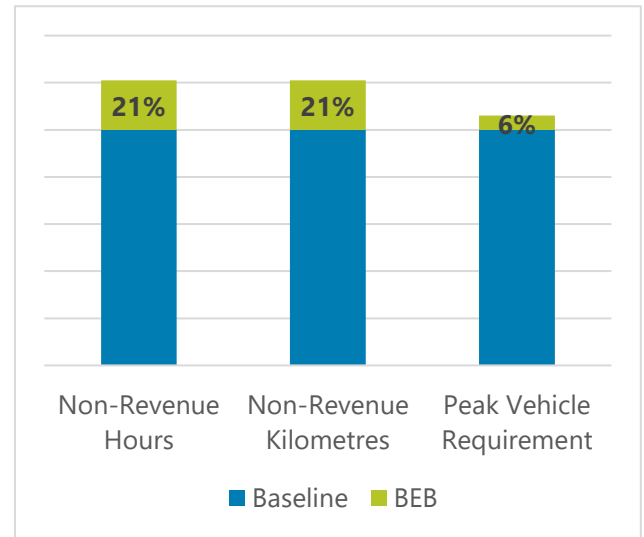


## MODEL RESULTS: 675 KWH BATTERY CAPACITY

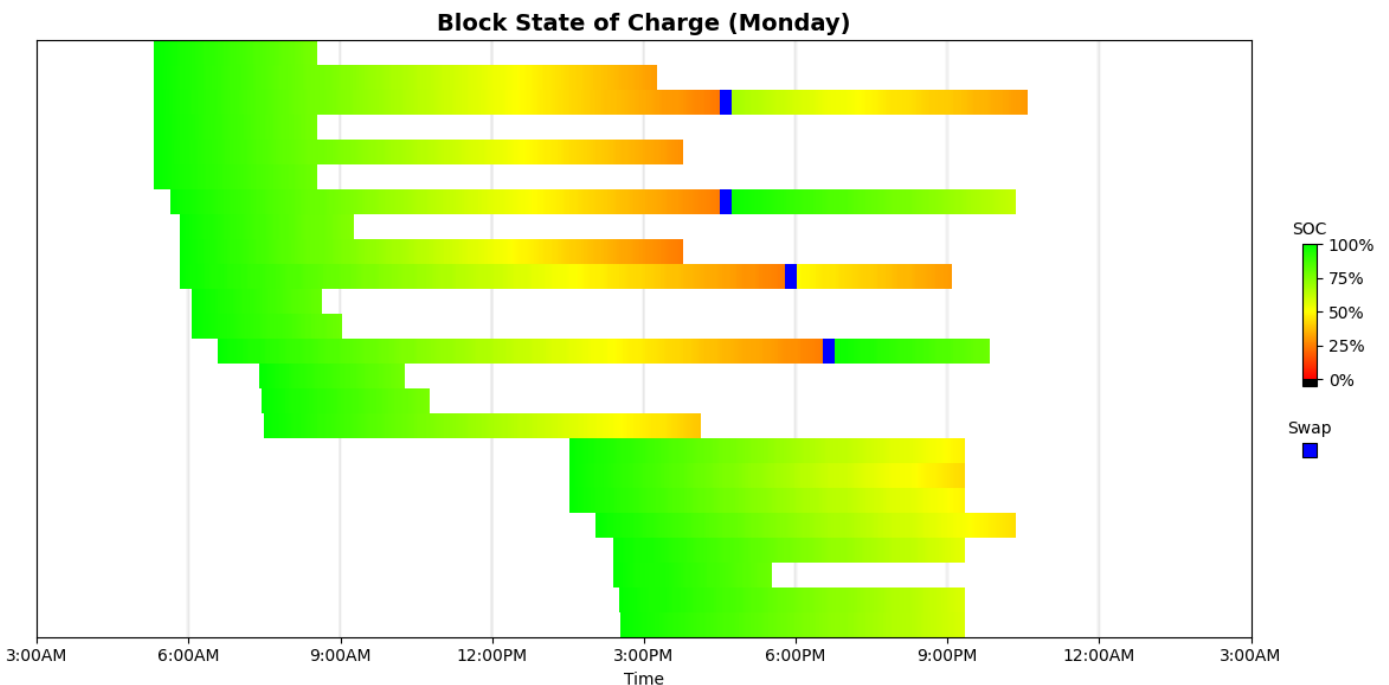
Below is a review of the main components of the transit service and operations that are likely to change and should be considered when transitioning to a 675kWh BEB fleet using depot charging only. **Figure 16** shows an estimate of the increase in non-revenue hours and kilometres as well as the estimated number of vehicles required to continue the current transit service.

- Revenue hours and kilometres remain the same
- Non-revenue hours: **21% increase**
- Non-revenue kilometres: **21% increase**
- Peak Vehicle Requirement: **6% increase**
- At least 4 depot chargers will be required:
  - (4) 150 kW plug-in chargers
- (12) 675kWh BEBs can be deployed before an increase in fleet size is required

With a 675kWh BEB, there are operational improvements in Milton service as only four blocks (three fewer blocks than the 525kWh BEB) are feasible with only one swap and the rest are feasible without swaps. The vehicle battery states of charge on each block during weekday service are shown in **Figure 17**.



**Figure 16. 675kWh BEB Depot Charging Only Model Outputs**



**Figure 17. 675kWh BEB Depot Charging Only - Weekday Service Block SOC Heatmap**



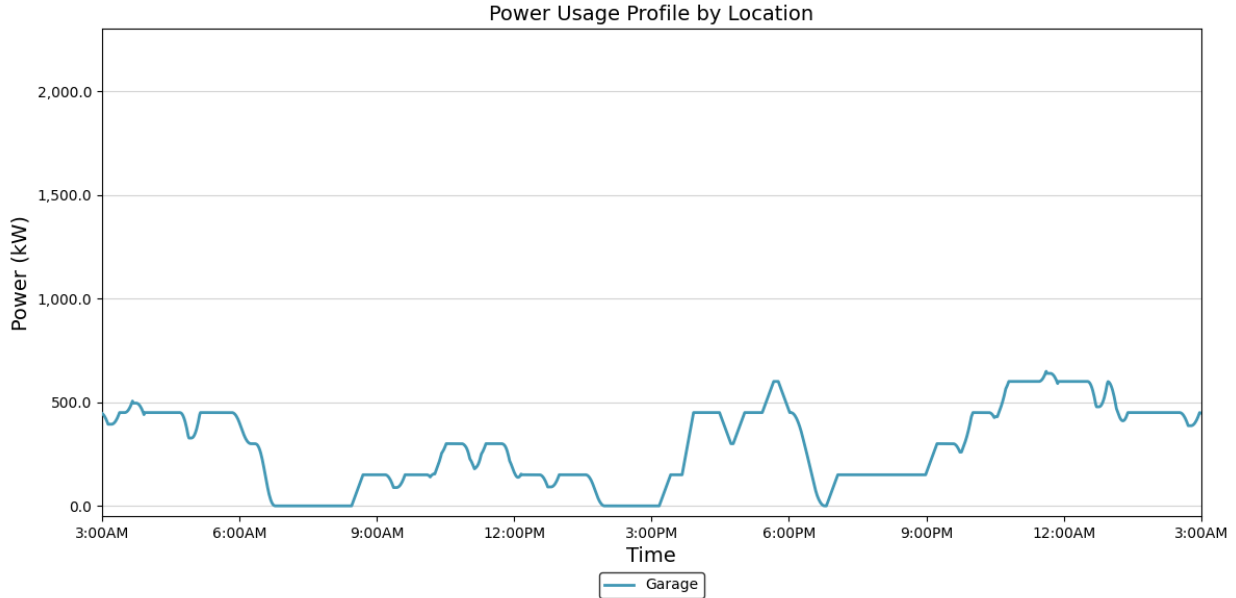
**Table 25** shows which service blocks are feasible with 675 kWh buses and infeasible, respectively. A total of 20 blocks (83%) can be replaced with BEBs at a 1-to-1 ratio without the need for en-route charging. The remaining 4 blocks (17%) would require either en-route charging or a bus swap to complete service.

**Table 25. Summary of Feasible Blocks without Swap for 675 kWh BEB**

Feasible with 675 kWh Bus			Infeasible with 675 kWh Bus
1225529	1225534	1225574	1225541
1225533	1225569	1225514	1225524
1225540	1225519	1225547	1225509
1225544	1225566	1225553	1225550
1225556	1225579	1225575	
1225557	1225580	1225567	
1225592	1225597		

**Power Requirements**

**Figure 18** shows the daily power demand profile for 675kWh BEBs at the depot facility if Milton Transit elects to continue with depot charging only. The power demand is highest in the evenings and overnight, peaking at 600 kW. This is primarily due to the buses returning to the depot facility and being plugged in. There is a peak in demand at 6 pm, and then between 11 pm and 6 am. Demand is relatively low between 7 am and 3 pm.



**Figure 18. 675kWh BEB Depot Charging Only Maximum Daily Power Profile at Depot Facility**

**DEPOT & EN-ROUTE CHARGING SCENARIOS**

This scenario evaluated a fleet of 525kWh BEBs with on-board diesel auxiliary heaters that would utilize plug-in depot chargers and overhead pantograph chargers en-route positioned at Milton GO Station. Layover times in the existing schedule were used to identify the most ideal locations for en-route chargers.



There was one location identified as having a significant amount of layover time available for buses to charge.

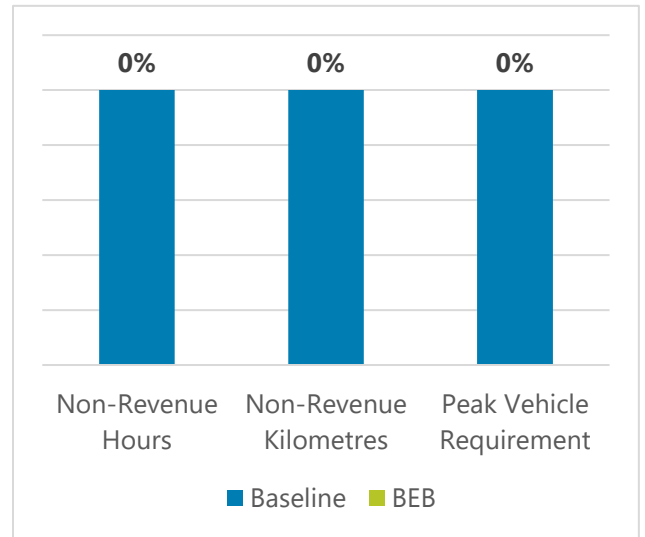
The review of the en-route charging locations does not consider the complexity associated with property ownership, access, existing utilities, and other site constraints that may limit or be prohibitive for these activities. This illustrative exercise would require additional study prior to committing to this work.

### MODEL RESULTS: 525 KWH BATTERY CAPACITY

Below is a review of the main components of the transit service and operations that are likely to change and should be considered when transitioning to a BEB fleet utilizing enroute charging in addition to depot charging. **Figure 19** shows an estimate of no increases in non-revenue hours and kilometres as well as no estimated increases in the number of vehicles required to continue the current transit service.

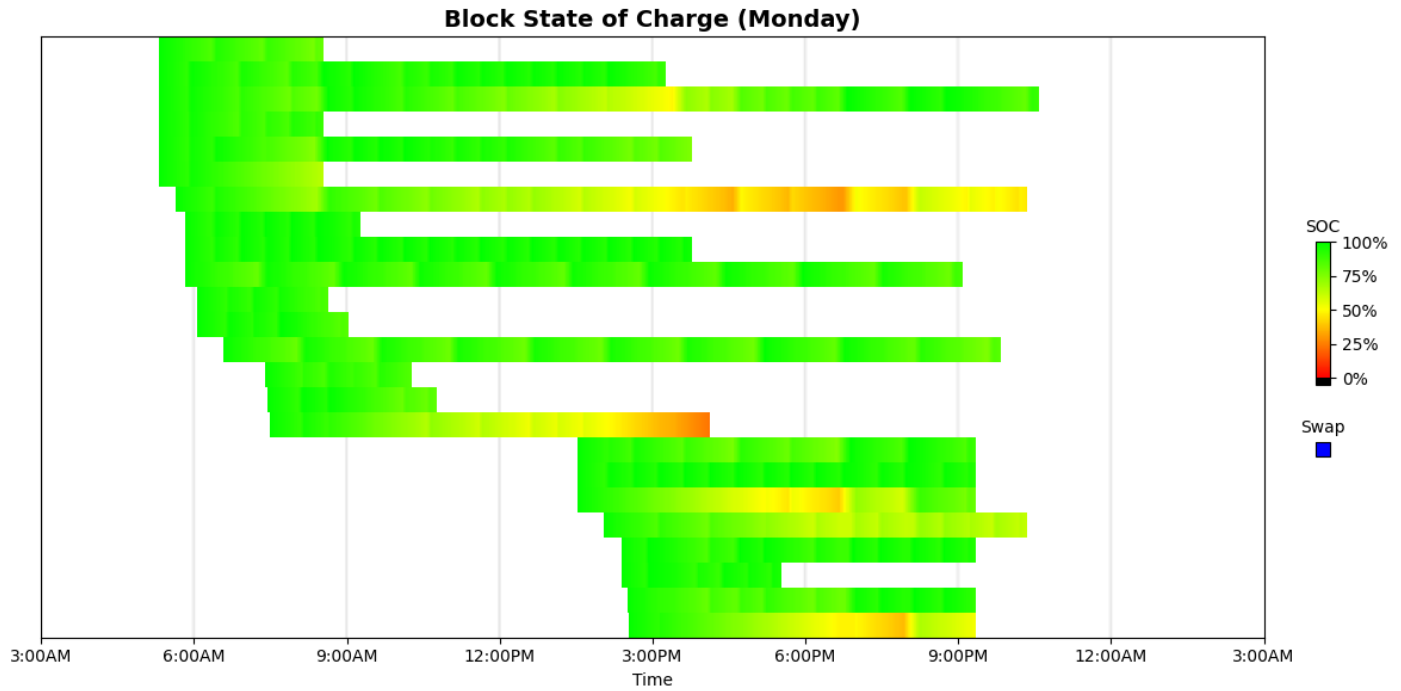
- Revenue hours and kilometres remain the same
- Non-revenue hours and kilometres remain the same
- Peak Vehicle Requirement remains the same
- At least 2 en-route chargers will be required:
  - (2) 450 kW pantograph chargers at Milton GO Station

With the introduction of en-route chargers at Milton GO Station, all service blocks can be completed without the need for schedule modifications or bus swaps as shown in **Figure 20**. Though en-route charging improves feasibility, there are several complexities the Town would need to consider at Milton GO Station.



**Figure 19. BEB Depot and En-Route Charging Model**



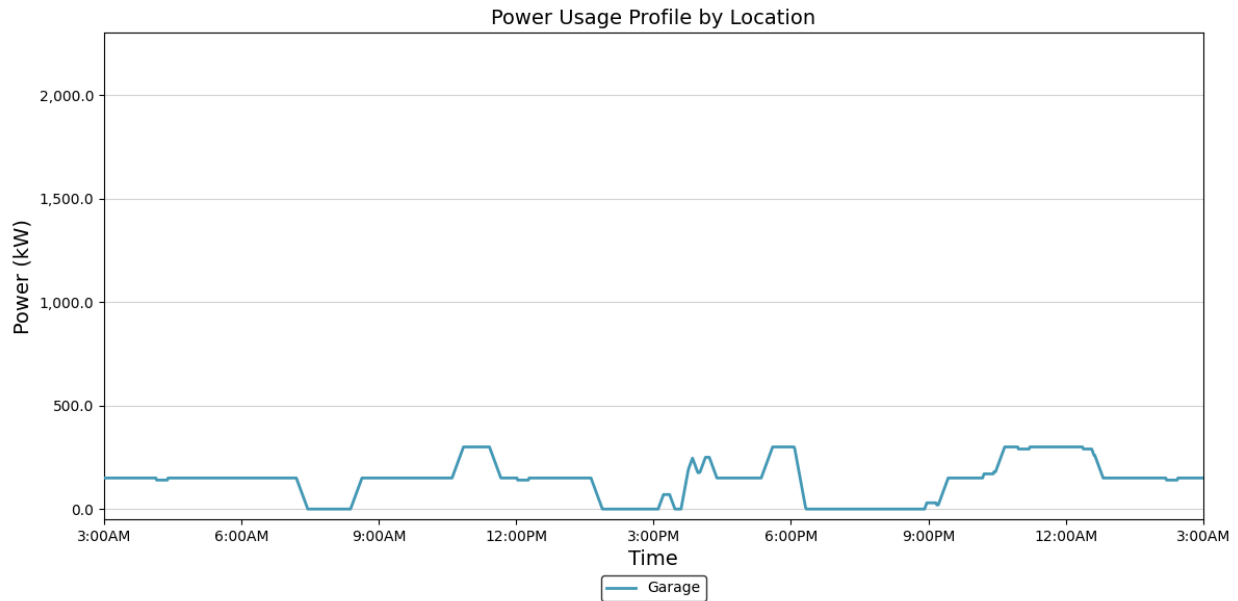


**Figure 20. 525kWh BEB Depot and En-Route Charging - Weekday Service Block SOC Heatmap**

**Power Requirements**

**Figure 21** shows the daily power demand profile at the depot facility, peaking at 300 kW, if Milton Transit elects to deploy en-route chargers in the future. The overnight peak demand is slightly reduced and the demand during the day is lower, and more uniform compared to the depot charging only scenario.





**Figure 21. Depot and En-Route Charging Maximum Daily Power Profile at Depot Facility**

## ON-DEMAND/SPECIALIZED SERVICE

Milton Transit on-demand services were modelled separately from fixed route services due to the available data types. The modelling effort for Milton Transit’s specialized fleet is based on operating data provided by the agency, as well as battery and charging specifications of BEB equivalents. Existing specialized vehicle average daily miles and hours were considered in the modelling, derived from provided monthly vehicle data. The total energy consumption of the BEB fleet is computed using the average-case vehicles to forecast overall site energy and fleet size impacts.

To protect the life of the BEBs’ batteries and avoid range anxiety, a minimum state of charge (SOC) of 20% and a maximum SOC of 90% to protect the life of the battery is assumed. These assumptions are reflected in the analysis by assuming a usable battery capacity equal to 70% of the vehicle’s nameplate battery capacity. The use of accessory equipment like wheelchair lifts can also impact the energy consumption, but the impacts are difficult to predict. Accessory equipment does not typically significantly impact energy consumption, but to account for unknown additional energy requirements a 10% energy consumption buffer was added to the daily energy needs of each vehicle that is equipped with a wheelchair lift.

If the daily amount of energy required exceeds the available energy for that vehicle type, then the cases for an increase in fleet size or mid-day fast charging are considered. These additional cases facilitate protecting the vehicle’s health while avoiding interruptions to normal operations. Three scenarios were considered: a baseline (business as usual) scenario, a scenario reflecting an expanded BEB fleet, and a scenario where the fleet is not expanded but mid-day recharging is supported.

## MODEL INPUTS

This energy modelling effort was conducted to understand the feasibility of fleet operations using BEBs and to forecast the magnitude of infrastructure needed to support a transition to a BEB fleet. **Table 26** lists the



operational profile of each vehicle modelled; a total of six Arbocs were modelled, assuming four active and two spares and flex profile vehicles are assumed to have the same operational profile as the other Arbocs in service for which data was available. The total energy consumption of the BEB fleet is computed using both the average- and worst-case vehicles, which allows overall site energy and fleet size impacts to be more accurately predicted.

**Table 26. Specialized Fleet Modelling Inputs**

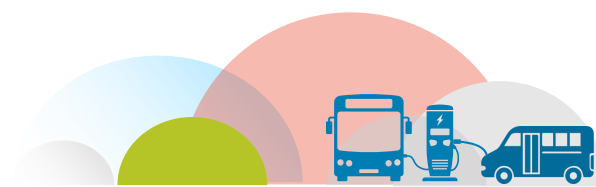
Vehicle ID	Quantity Modelled	Average Daily Time (Hours)	Max Daily Time (Hours)	Average Daily Distance (km)	Max Daily Distance (km)
M2031 (Arboc)	3	7:27:06	11:36:00	144.42	249.03
M1922 (Promaster)	1	7:58:36	16:31:12	163.88	457.35
M1923 (Promaster)	1	8:35:18	21:19:48	180.83	531.78
M1921 (Promaster)	1	8:29:55	14:43:48	161.39	411.28
M2021 (Promaster)	1	11:43:56	30:59:24	233.84	545.79
M1924 (Promaster)	1	7:58:39	11:43:12	157.9	362.46
M2022 (Promaster)	1	7:59:57	12:42:00	166.82	398.74
M2032 (Arboc)	3	7:35:06	8:51:00	150.36	209.45

## MODEL RESULTS

Milton Transit’s specialized fleet can complete most routes on an average day without any increase in required fleet size or the use of DCFCs depending on the operational profile. On a worst-case day, no vehicles can complete their service on a single charge without fleet or service modifications. Two alternate scenarios were modelled, where either the fleet size increases or vehicles are brought back to the depot facility for charging mid-day.

## BASELINE SCENARIO

First, a baseline scenario was modelled to identify the number of vehicles and chargers required to support a BEB fleet based on current operating characteristics. **Table 27** shows which vehicles can complete service on a worst-case day and which cannot. This model illuminated challenges with some BEBs’ ability to complete the service required of them on a single charge as shown in the Average Day Feasibility and Worst Case Day Feasibility columns below.



**Table 27. Baseline Scenario Model Results**

Vehicle ID	Average km	Max km	Shift Length	Shifts	Average Day Feasibility	Worst Case Day Feasibility
M2031 (Arboc)	144.42	249.03	10.00	1	Feasible	Infeasible
M1922 (Promaster)	163.88	457.35	10.00	1	Feasible	Infeasible
M1923 (Promaster)	180.83	531.78	10.00	1	Feasible	Infeasible
M1921 (Promaster)	161.39	411.28	10.00	1	Feasible	Infeasible
M2021 (Promaster)	233.84	545.79	10.00	1	Infeasible	Infeasible
M1924 (Promaster)	157.9	362.46	10.00	1	Feasible	Infeasible
M2022 (Promaster)	166.82	398.74	10.00	1	Feasible	Infeasible
M2032 (Arboc)	150.36	209.45	10.00	1	Feasible	Infeasible

The vehicles reaching maximum distance per day experienced battery capacity utilization challenges, leading to the need for an increased fleet size to facilitate bus swaps or mid-day recharging at the depot facility. Without these accommodations, the fleet would not be able to complete their service.

## EXPANDED FLEET SCENARIO

This model scenario assumes that all vehicles that were feasible on a worst-case day remain unchanged, but the five vehicles that could not meet service requirements are assumed to be swapped on-street with a fully charged vehicle to finish service. When daily mileage exceeds the range capability of the BEB, the model will add an additional vehicle to the fleet. Vehicles would remain on the street until their battery reaches 20% SOC and then would be swapped with a fully charged bus for the remainder of service. To accommodate bus swaps, the fleet would need to increase by 8 vehicles, one for each active vehicle reaching the maximum daily distance. **Table 28** indicates the *minimum* infrastructure that would be needed to maintain service but, in practice, the fleet may be charged by higher powered chargers.

**Table 28. Expanded Fleet Scenario Analysis**

Vehicle ID	Daily Maximum Distance (km)	BEB Fleet Size	Minimum Charger Level & Output	Peak Load (kW)	Maximum Daily Energy Consumption (kWh)
M2031 (Arboc)	144.42	4	15 A Level 2	14.4	221.5
M1922 (Promaster)	163.88	2	15 A Level 2	7.2	151.8
M1923 (Promaster)	180.83	2	15 A Level 2	7.2	166.2
M1921 (Promaster)	161.39	2	15 A Level 2	7.2	149.5
M2021 (Promaster)	233.84	2	30 A Level 2	14.4	180.0
M1924 (Promaster)	157.9	2	15 A Level 2	7.2	146.1
M2022 (Promaster)	166.82	2	15 A Level 2	7.2	153.6
M2032 (Arboc)	150.36	4	15 A Level 2	7.2	228.9





## MID-DAY RECHARGING SCENARIO

To identify the infrastructure needs of a BEB fleet supported by mid-day recharging, another scenario was modelled where the overall fleet size does not change from the current fleet size, but vehicles are brought back to the depot facility during the day to recharge between shifts. Similar to the expanded fleet scenario, only 1 vehicle would need to be brought back to the depot facility on an average day, but on a worst-case day all vehicles would need to return for mid-day recharging at least once throughout the day to maintain the same level of service. In the model, this is reflected by splitting one shift into either two 5-hour shifts or three 4-hour shifts, depending on the operational profile of the vehicle. When breaking down the existing profile into multiple shifts, all vehicles can complete service on both an average and worst-case day without the need for an increase in fleet size. **Table 29** indicates the *minimum* infrastructure that would be needed to maintain service but, in practice, the fleet may be charged overnight by higher powered chargers; mid-day recharging would utilize the transit fleet’s DCFCs and would require between 54 and 79 minutes to recharge between shifts.

**Table 29. Mid-Day Recharging Scenario Analysis**

Vehicle ID	Shift Maximum Distance (km)	Shifts	BEB Fleet Size	Minimum Charger Level & Output	Peak Load (kW)	Maximum Daily Energy Consumption (kWh)
M2031 (Arboc)	124.515	2	3	30 A Level 2	21.6	88.4
M1922 (Promaster)	152.45	3	1	30 A Level 2	7.2	28.8
M1923 (Promaster)	177.26	3	1	30 A Level 2	7.2	32.2
M1921 (Promaster)	205.64	2	1	30 A Level 2	7.2	41.7
M2021 (Promaster)	181.93	3	1	30 A Level 2	7.2	39.5
M1924 (Promaster)	181.23	2	1	15 A Level 2	3.6	39.9
M2022 (Promaster)	199.37	2	1	30 A Level 2	7.2	42.4
M2032 (Arboc)	104.725	2	3	30 A Level 2	21.6	89.2



## APPENDIX B: FACILITY ASSESSMENT

### DEPOT CHARGING

Depot charging refers to the siting and use of charging infrastructure at the facility where buses are typically stored overnight. At the depot, the main difference between plug-in and pantograph dispensers is the way the vehicle is connected to the charger. Charging speeds will be similar because both dispensers use the same charging modules to deliver the same amount of energy.

There are trade-offs with picking either plug-in or pantograph as the connection option. Pantographs take up less space if mounted to existing overhead structures and can offer an automatic way of connecting the vehicle that doesn't require an operator or service person to physically plug in a cable. Some of the drawbacks are that they're heavier, more expensive (estimated 2x due to structure construction and additional equipment), require more maintenance, require precise vehicle alignment under the pantograph, and interference with wireless communication between the dispenser and the bus may lead to disruptions in the charging process.

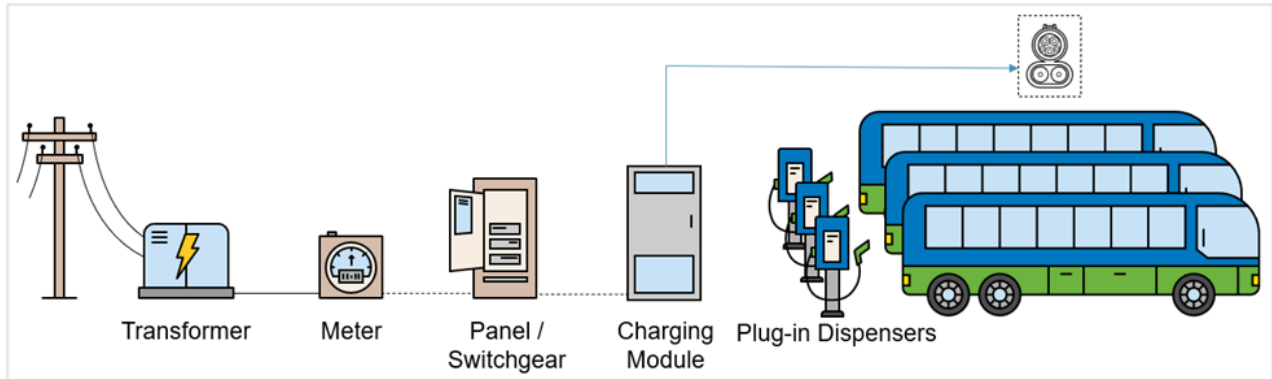
Plug-in charging (**Figure 22**) has the benefits of typically being less expensive, with fewer physical alignment issues and typically fewer communication issues (since there is a hard-wired communication between the charger and dispenser and dispenser and the bus). The downsides are that someone must physically plug the bus in, it typically takes up more floor space (but can also be mounted to the ceiling), requires cable management, and plug-in connectors are more easily damaged.

The CCS plug-in charging standard, SAE J1772 model, has been around since 2011 and is a more mature standard that has received several revisions. The first version of charging standard for pantograph down, J3105-1, was published in 2020. At present, some aspects of the standard are being refined to address some of the issues mentioned above.

For the depot facility, a dispenser for each bus is recommended to ensure that when the fleet is parked at night all vehicles can be charged without the need to circulate buses through a limited number of charging bays. It is likely that there will be times when a charger or dispenser will occasionally be out of service due to failure or routine maintenance. Since transit fleets typically maintain a fleet size that includes several spare buses beyond the number required to meet peak service each day, having at least one dispenser per bus will also provide for resiliency in that there will effectively be spare chargers.

Manufacturers offer products that enable several dispensers to be powered from a single charging cabinet. This can be achieved either through "sequential charging," where buses are put in a queue and charged individually, or through "parallel charging," where power is shared among multiple connected vehicles. This infrastructure reduces the amount of charging modules required and provides multiple dispensers and charging options. Despite this advantage, the failure of a single charging cabinet can impact the charging of multiple buses.



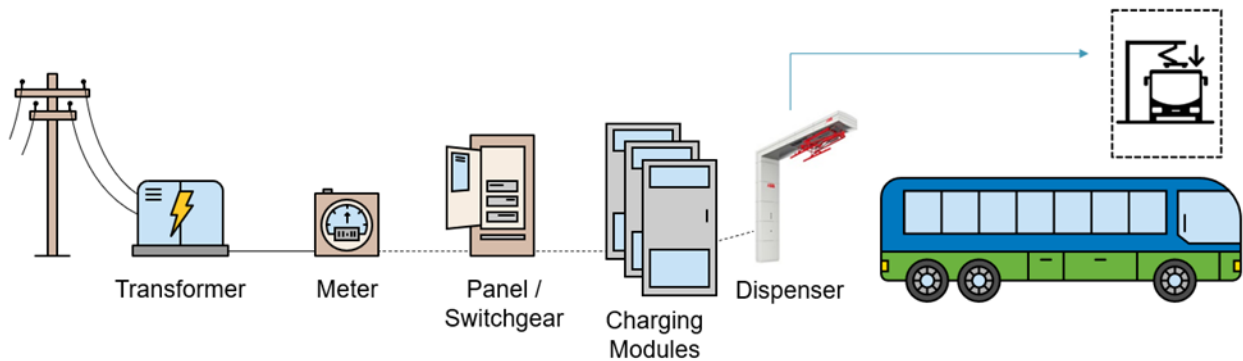


**Figure 22. Equipment Required to Feed a Single Charging Module with 3 Plug-In Dispensers**

Charging modules come in different sizes and power levels depending on the amount of charging required. Some modules can serve up to four dispensers, with the majority of chargers capable of serving up to three dispensers. Regardless of size, it's important to match the number of dispensers to the number of vehicles stored at the facility.

## EN-ROUTE CHARGING

En-route or layover charging is a term used for high-speed charging infrastructure that is placed along a bus route (**Figure 23**). This infrastructure allows BEBs to charge during layover time, which can be as little as 5 minutes, in order to regain some or all of their energy. The current en-route chargers have a rating of approximately 450 kW; however, no bus can currently accept that much power, so several charger manufacturers have begun to reduce their largest charger offering to between 300 and 360 kW. Should future bus models begin to accept higher power charging, the charger size may increase in the future.



**Figure 23. Equipment Required to Feed a Single High-Speed Pantograph Charger**

Typically, all the charging equipment in **Figure 23** will be required on each en-route site, but sites with multiple en-route chargers are able to share larger transformers and switchgear. Charging modules can be separated from the dispensers by 100 metres with some manufactures extending to up to 150 metres. Charging modules and upstream electrical equipment should be in “back of house” areas away from passengers, if possible. Having electrical equipment located away from passenger areas makes it easier for repair and servicing without impacting the public. Charging modules also generate heat and minimal noise



when in operation which is not ideal for customers. Locating charging modules in fenced compounds is further recommended to avoid risk of vandalism.

En-route quick charging requires a large amount of power for each charging station. Facilities that have separate drop-off, layover and pick-up areas are ideal for en-route charging since a fast charger in the layover location can potentially serve multiple routes. Terminus locations without separate drop-off/layover/pickup locations can also use en-route charging but may require additional pantograph dispensers that will allow for charging at the gate where vehicles normally park for the duration of the layover.

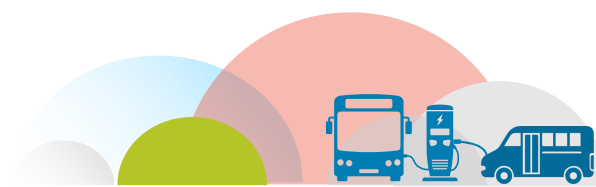
## CHARGING INFRASTRUCTURE CONSIDERATIONS

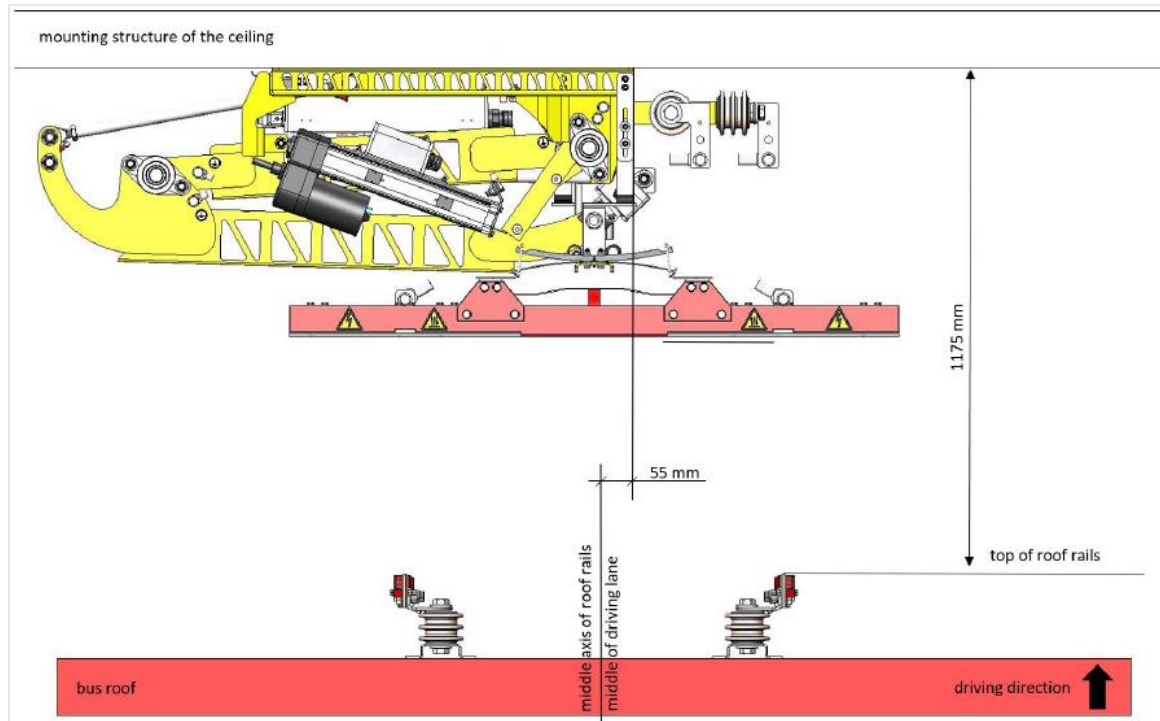
The following sections list factors that were considered when developing the concept plans. They were developed using industry best practices and considered the fact that the Town has the ability to design a brand new facility to accommodate EV charging infrastructure.

### DEPOT CHARGER SELECTION

There are currently a number of charging solutions, including plug-in, pantograph, and wireless inductive charging available for use in transit applications. For Milton Transit, facility space planning constraints may restrict the type of charger dispensers that are operationally feasible. For charging in the indoor parking structure, wall mounted chargers would be a good option for the two outer most parking lanes; while for the four inner parking bays, either would employ overhead retractable plug-in cable reels or overhead pantograph chargers could be installed. These options minimize space requirements within the building by eliminating the need for bay restriping to include space for ground-mounted dispensers and protective bollards.

As the Town is designing its new facility, it should consider designing its roof height to accommodate overhead pantograph charging for the rows of inner parking bays that are not adjacent to a wall. Pantographs are an option for space-saving charging infrastructure. Pantographs require that they be mounted at a particular height above the vehicle. As shown in **Figure 24** the typical depot pantographs need to be mounted around 1.175m above the bus. With the ceiling structure being 5.5m to 6.5m above the ground, the application may require a separate gantry or ceiling mounted structure to support the pantograph at the appropriate height, being around 4.5m off the ground.





**Figure 24. Wabtec Optimal Installation Position of Depot Pantograph**

Ceiling- or wall-mounted cable retractors (**Figure 25**) that have enough cable range to reach the vehicles are a viable option. However, a detailed design is necessary to identify specific locations and determine whether any conflicts with other infrastructure exist where the equipment would be mounted. Motorized cable reels that raise and lower the connectors when not in use are also available. When using motorized retractors, there should also be consideration given to how the reels will be activated, such as by pull cord, remote switch, or other automated custom solutions, or other available options.





**Figure 25. Example of Wall Mounted Cable Reel**

## ROOF STRUCTURAL LOADING

During the new facility design, the structural capacity will need to be designed to accommodate the additional weight of the pantograph or charger reel. The weights of equipment can vary significantly by manufacturer, and this may limit which types of dispensers could be used if mounting to the ceiling structure. In some cases, powered cable reels can be mounted on the wall to avoid putting additional weight on the roof structure of a building. The installation cost between the pantographs and cable reels is not significantly different.

**Table 30** provides information gathered from manufacturer specification sheets. It should be noted that the cable reel dispensers have a significant advantage in terms of the usable range between the dispenser and the bus which can make them a good option for areas with high ceilings.

**Table 30. Dispenser Weight and Dimension Specifications of Select Manufacturers**

Type	Manufacturer	Model	Weight	Useable Range	Dimensions
Pantograph	Wabtec	ChargePANTO	387 kg	1.50 – 1.7 m	2247 x 1250 x 574 mm
Pantograph	Wabtec	DepotPANTO	90 kg	1.0 m max	1524 x 825 x 475 mm
Pantograph	Schunk	SLS 301	90 kg	0.36 m max	1580 x 1020 x 1000 mm
Cable Reel	Wabtec	ChargeREEL	125 kg	6.7 m max	900 mm reel diameter

## EN-ROUTE PANTOGRAPH CHARGERS

It is important to monitor the utilization of pantograph chargers if they are deployed for en-route charging. To secure a charge, drivers must align the vehicle correctly with the charger. One way to help drivers align the vehicles is by implementing a system, such as an indicator, that they can use for positioning. Some



agencies have used markers both inside and outside the bus and/or speed bumps to help with positioning as shown in **Figure 26**. Given that potential charging stations at transfer points would be situated outdoors and exposed to snow, relying on on-ground markers may not be the best approach for Milton Transit. It may be more practical to adopt another method, such as aligning the front bumper with a landmark that won't be obstructed by snow in the winter, like a bus stop sign.



**Figure 26. Example of Alignment Markers for Proper Bus Positioning<sup>11</sup>**

## UTILITY COORDINATION

Unanticipated utility infrastructure costs and long lead times for critical equipment such as transformers are causing delays for implementing fleet electrification, but the Town's anticipated construction date in 2026 provides sufficient time to address these barriers. Furthermore, it will be important for the Town to understand how Milton Hydro's approved rate tariff will impact its fleet's charging costs.

As the Town is currently in the conceptual stages of facility planning, it was determined that a conversation with Milton Hydro about site specifics was premature. Therefore, a series of considerations is provided below for the Town to consider as they coordinate with Milton Hydro on the design.

## FACILITY UTILITY CONSIDERATIONS

Currently, most EV charging infrastructure is designed to operate at 480 V which is commonly used in the US. If Milton Hydro is unable to provide a 480V connection and instead can only provide a 600V connection,

<sup>11</sup> Source: [Guidebook for Deploying Zero-Emission Transit Buses | Blurbs New | Blurbs | Publications \(trb.org\)](#)





a step-down transformer will need to be purchased to serve the charging equipment. By the time the Town is ready to construct its facility, more EV vendors may offer 600V equipment rated for Canada. The step transformer cost is dependent on size, ranging from \$40,000 USD for 300 kVA to \$70,000 USD for 1000 kVA).

## SITE CONSTRAINTS

A new bus depot facility is currently being considered for construction. Site constraints of the proposed facility are not known at this time. The facility should have access to adequate electrical utility infrastructure that can provide the anticipated energy needed for the electric bus conversion.

## PRIMARY AND SECONDARY METREING

Typically, utilities provide service connections to clients either as primary or secondary metered services.

For a primary metered service connection, the utility brings power to the client at distribution and transmission voltage. The client is responsible for designing, constructing, owning, operating, and maintaining a substation or other medium voltage electrical equipment to step this voltage down and distribute it throughout the facility. Metering equipment for the client is done at the distribution/transmission voltage which is more costly than the equipment required for secondary metering but results in a lower cost per kwh. The client may also choose a primary service even if their power requirement can be provided as a secondary service if the client needs a different voltage than what the utility can supply as a secondary service voltage. The primary meter cost will vary depending on the utility.

Secondary metering service connections have a transformer owned and maintained by the utility that reduces the voltage from the primary distribution voltage to a standardized lower voltage, either 600 V three phase, 208 V three phase, or 120-240 V single phase. With a secondary metering service, a utility meter is then installed downstream of the transformer. Secondary services are generally preferred because they are less expensive and maintained by the utility. However, secondary services can be limited to a maximum service size that is determined by each utility.

Since the new Milton bus depot location has not yet been determined and the potential en-route location may undergo substantial redevelopment, conversations with the utility regarding existing capacity were not completed at this time. Milton should begin discussions with the utility as soon as possible, even while selecting the property as the utilities ability to serve a large bus charging load could have a potential impact on necessary utility feed improvements and costs required to provide adequate power to the site.

## REDUNDANT FEEDS

For critical infrastructure such as that which would power Public Transit services, redundant power feeds to a site are used to increase the reliability of the utility service. This is commonly achieved by bringing a separate circuit to the site that is fed from a different circuit and power line, preferably from a separate substation.

If the redundant feed comes from the same substation and a different circuit this only protects the site from an outage on one of the power lines, such as a tree falling on the power line or a pole breaking. In the event of an outage at the substation, both feeds may experience an outage depending on how the utility designed





or operates the system. For this application, a redundant feed from the same substation is only practical if an alternate circuit is already nearby the site, otherwise a new power line would need to be brought to the site from the nearest location, which can be cost prohibitive. Redundant feeds from a separate substation provides the most robust utility feed for a site and are recommended whenever possible as they can be less costly and more reliable than other redundant sources. Energy resiliency is discussed elsewhere within this appendix.

## ELECTRICAL INFRASTRUCTURE OWNERSHIP

Some municipalities in other regions have looked to partner with their local utilities to install and maintain electrical infrastructure and charging equipment. Business models such as charging as a service (CaaS) and energy as a service (EaaS) are two examples where a third-party service provider offers energy-related assets and services to customers.

CaaS focuses specifically on providing EV charging infrastructure, whereas EaaS encompasses a wider range of energy-related assets and services, including energy storage, renewable energy sources, and energy management systems. Working with local utilities or third parties there may be an opportunity to leverage their expertise to allow the transit agency to focus on its core business which is operating transit service. Utilities have expertise in electrical infrastructure maintenance, energy management, energy market trends, renewable energy and regulatory compliance that can ensure that charging infrastructure is installed and scaled to meet the demands of the transit agency, and that energy usage is optimized to minimize costs.

Reliability and backup power are also critical components that can be included in EaaS agreements and are often factored into the service level agreements (SLAs) between the EaaS provider and the customer.

In utility discussions with Milton Hydro, the Town can bring up these alternative options for consideration.

## UTILITY RATE CONSIDERATIONS

Electrical costs are determined based on the utility's approved rate tariff which in Ontario is regulated and approved by the Ontario Energy Board (OEB). In Ontario's energy system, customers are classified into two categories: Class A and Class B.

A Class A customer in Ontario's energy system refers to a larger business or industrial customer that has an average peak demand of more than 5 megawatts (MW) in any of the previous twelve months. These customers have the option to participate in the Industrial Conservation Initiative (ICI) program, which allows them to reduce their Global Adjustment (GA) charges by reducing their electricity consumption during periods of peak demand.

A Class B customer refers to a residential or smaller business customer that has an average peak demand of less than 5 MW in any of the previous twelve months. These customers are charged a regulated price for the electricity they consume, which is set by the OEB and is based on the Hourly Ontario Energy Price (HOEP). Class B customers also pay a GA charge calculated on an hourly basis and is included in the overall electricity price that Class B customers pay.



Customers in Ontario also have the option of purchasing electricity from third party energy retailers approved by the OEB. When purchasing electricity through energy retailers, customers are still responsible for other aspects of electricity like delivery, regulatory and global adjustment charges.

- **Monthly Service Charges (\$):** Base charges, assessed monthly included for every meter location. This likely will not change with adding BEB's to the fleet.
- **Energy Consumption Charges (\$/kwh):** Charges for quantity of electrical energy consumed over a monthly period. Charge is based on kilowatt-hours (kWh) that are used, and the price Milton Transit will pay depends on the time of day and time of year the BEBs are charging vehicles from the grid. (See below).
- **Demand Charges (\$/KW):** Demand is measured in kilowatts (kW) and the demand charge is a \$/KW fee assessed based on the highest kW level drawn in the monthly billing period. This charge is of particular importance to fleet managers of BEBs. For example, if Milton Transit charged BEBs in the middle of the afternoon at the exact time it is drawing its peak power for its other electric services, this may significantly increase its monthly demand charge. The use of charge management systems can help mitigate the effect of demand charges with BEBs and other EVs.

## APPLICABLE UTILITY CHARGES

Based on the Milton Hydro utility rates ([Milton Hydro - Electricity Rates](#)), time-of-use rates were updated on November 1, 2023. Milton Hydro has three General Service rate schedules and one Large User (over 5,000 kW) schedule. Based on the predicted energy consumption to electrify the existing bus fleet, four chargers would peak at approximately 600 kW, which would qualify for the General Service 50 kW to 999 kW rate schedule. Increased fleet size may require additional charging load and may push Milton Transit to one of the larger rate categories (i.e. General Service 1,000 to 4,999 kW or Large User).

- **Monthly Service Charges:** The Milton Hydro Monthly Service Chargers include a Customer Charge and a \$0.25 SSS Administration Charge. The Customer Charger is \$86.74 for the 50 to 999 kW and \$682.42 for the 1,000 to 4,999 kW General Service categories.
- **Demand Charges:** There are numerous demand charges that apply to Milton Hydro rates including Distribution Variable, Transmission Network and Connection, rate riders, etc. Excluding the riders, the Demand Charges range from \$11.4941 to for 50 to 999 kW and \$10.1767/kW for the 1,000 to 4,999 kW General Service categories, respectively.
- **Energy Consumption Charges:** Energy consumption charges can be difficult to predict with some rate schedules. Milton Hydro includes \$0.0052/kWh for regulatory charges. Milton Hydro's rate schedule does not appear to vary with rate category. Milton Hydro currently charges \$0.182/kWh for On-Peak, \$0.122/kWh for Mid-Peak, and \$0.087/kWh for Off-Peak winter rates, but the online rate schedule doesn't indicate to which service class these apply. Winter rates run from November 1 through April 30, while Summer rates run from May 1 through October 31. Off-peak rates occur from 7 PM to 7 AM under both seasonal schedules while Mid- and On-Peak rates vary depending on season.



## CHANGING UTILITY RATE STRUCTURES

It's important to note that the demand for electricity is increasing, partly due to the shift towards clean electricity in fleets and building systems. This increase in demand is causing some utilities in North America to modify their rate structures. The following are examples of different rate structures that utilities have implemented to accommodate the rising demand. These examples are intended to provide insight into how rates may evolve in the future.

## SEASONAL CONSIDERATIONS

Many utilities utilize seasonal rates during different times of year. These rates generally reflect the rate changes from the bulk power provider and generally charge less when less is consumed (i.e. summer when daylight hours are longer and temperatures are more moderate).

Milton Hydro already utilizes Winter and Summer seasonal rates and will likely continue to do so.

## TIME OF USE (TOU)

Some utilities also utilize TOU rates to incentivize customers to consume power during off-peak times, when possible, thus creating a peak-shaving effect. This approach allows utilities to defer large infrastructure projects that would otherwise be needed for high peak consumption but then not utilized during the majority of time. TOU rates also help to better regulate generation needs and mitigate costs.

Milton Hydro already utilizes TOU rates and will likely continue to do so.

## ELECTRIC VEHICLE CHARGING RATES

Some utilities are beginning to incentivize electric vehicle adoption with specific EV tariff structures. These tariff structures are designed to accommodate the unique electricity needs of EV's and EV fleets, and to incentivize EV charging at times that are optimal for the grid. For example, the Ontario Energy Board (OEB) is introducing an "ultra-low" overnight rate for residential customers. As of 2023, this structure is not applicable to Milton Transit's fleet.

## SEPARATE METRES/FEEDS FOR EV CHARGING

Many utilities have been employing a separate service and meter for electric vehicle charging. This meter is separate from the rest of the facilities at the site and means that it only measures the demand and consumption of EV charging.

Separate meters allow for the utility to isolate the demand and consumption of vehicle charging compared to other loads at the site which can allow them to apply discounted EV electricity rates. Separate meters or sub-meters are typically recommended for EV charging infrastructure even if the utility does not currently offer an EV rate. Utility tariffs are constantly changing and if an EV charging rate becomes available in the future, additional metering modifications will not be required.

Another reason this is preferable is that different departments within the Town are responsible for different expenses, such as bus operations for charging versus administration for building electrical and outside lighting. Separate meters or sub-meters will allow the Town to understand how much of their energy costs are going to move the fleet compared to normal building loads.



## SOLAR GENERATION RATES

There are a few ways the PV system can benefit on-site loads. First, PV provides local power generation to offset the loads and reduce, or negate, the overall load during PV generation hours. In instances where the PV system is generating more energy than the load requires, the system can generate revenue through a net metering program. In the case of net metering, the excess solar energy is sold back to the grid/utility at a wholesale rate, which is typically less than the purchase price of energy, and the amount is credited to the owner's utility bill.

Due to most net metering policies, energy generated on-site from PV is most valuable when utilized to feed on-site loads. Further coordination with the utilities is recommended to ensure that future utility rates will allow for net metering and to understand any potential caveats or limits associated with it.

## MAINTENANCE AREA CONSIDERATIONS

### MAINTENANCE BAY CHARGING

It is not expected vehicles will be routinely charged in maintenance bays, however, there may be instances when having some charging capability in the maintenance bays can be useful. For example, in case of a charging issue with a vehicle, it can be placed in a maintenance bay to diagnose the problem.

Portable chargers are available that could be shared between maintenance bays and deployed as needed. They would require appropriate power for the equipment to be available to the maintenance bays which could be connected by a Mennekes connection and relocated between maintenance bays as needed.

### VEHICLE ROOFTOP ACCESS

BEBs have a significant amount of equipment mounted on the roof of the vehicles including electrical converters, battery packs, and charging rails that will require service and/or troubleshooting. Fall protection systems will need to be in place that enable staff to safely work on those components of the vehicle. While personal fall protection equipment such as harnesses and retractors can allow this type of work to be done, the preferable way is to have permanent or portable scaffolding that allows staff to work on equipment without the need for personal fall protection equipment.

### LIFTING DEVICES FOR ROOFTOP EQUIPMENT

Along with access to the roof of the vehicle, it may also be necessary to be able to lift items like battery packs on or off the roof for service and replacement. The capacity of cranes attached to the roof should be checked against the heaviest equipment the manufacturer expects will need to be moved on or off the roof of the vehicle.

### SPARE PARTS STORAGE

Having an adequate supply of spare parts that will be unique to the BEBs and charging infrastructure is something that is recommended. With fewer vehicles on the road compared to internal combustion engine (ICE) vehicles, parts can have longer than normal lead times and having critical spares for both BEB and ICE vehicles will be necessary as the fleet transitions. The space requirement for those additional spare parts should be evaluated once information from the supplier has been provided in terms of the recommended quantity and type of critical spares.



## FLOOR AND HOIST CAPACITY

The empty vehicle weight of a BEB is typically heavier than that of diesel bus due to the significant weight of battery packs in the vehicle. This varies by manufacturer and battery pack configuration. Publicly available curb weights of several diesel, hybrid and BEBs are listed in **Table 31** to illustrate the magnitude of the weight difference between the different vehicle types.

**Table 31. Curb Weight of BEBs from Select Manufacturers**

Propulsion	Manufacturer	Model	Curb Weight
Diesel	Nova	LFS	12,981 kg
Battery Electric	Nova	LFSe+	16,002 kg
Diesel	New Flyer	Xcelsior	12,587 kg
Diesel-Hybrid	New Flyer	Xcelsior Hybrid	13,200 kg
Battery Electric	New Flyer	Xcelsior Charge NG	15,440 kg (480 kWh)*
Battery Electric	Proterra	ZX5 Max	15,131 kg (440 kWh)*
Battery Electric	BYD	K9MD	16,089 kg (496 kWh)*

*\*Note: Curb weights are from Altoona testing reports. Configuration options such as higher capacity battery packs can significantly impact vehicle weights.*

The structural capacity of the concrete floor inside the garage should be assessed to understand the impacts of operating heavier vehicles. If sufficient as-built information is available for the facility this may be able to be done through a desktop engineering analysis. If capacity of the flooring is unable to support heavier vehicle types, it may be possible to purchase lighter vehicles or consider if modifications could be made to the existing foundation.

To evaluate the vehicle hoist capacity, the actual weight of vehicles purchased should be compared to the hoist capacity at the transit garage to ensure that the current equipment is capable of safely lifting the vehicles. Weight distribution of BEBs can be more disproportionate than diesel buses so it's important that manufacturers are able to provide not only total curb weight but also the specific weight on a per axle basis.

## SOLAR AND BATTERY ENERGY STORAGE

Some transit agencies deploying BEBs add distributed energy resources like solar panels and battery energy storage systems (BESS) for added benefit. Understanding how these resources could be deployed and operated at existing and proposed facilities will assist in determining potential benefits for Milton Transit.

## SOLAR PHOTOVOLTAICS (PV)

Solar PV is an increasingly popular choice for on-site supplemental energy generation as solar costs have decreased significantly over the last decade. Solar PV is typically not capable of offsetting the entire bus charging energy demand. However, PV can offset a meaningful portion of overall demand resulting in a "net load" that is lower than scenarios without PV. The overall impact of solar PV is dependent on a fleet's charging schedule. A solar installation will have a greater impact on demand charges, and thus, a utility bill, if fleet charging is aligned with solar PV production. Even if day-time fleet charging is limited, the integration of on-site solar may help offset Milton Transit's increased load.



The PVWatts® Calculator was used to estimate the solar energy that could be generated at the conceptual site. PVWatts® is a tool created by the National Renewable Energy Laboratory (NREL) and uses the location and weather data for each site to estimate a monthly generated power output of the solar PV system, including overall system efficiency losses.

The planned roof for Phase I (including office and storage) has a total area of 7,940 square metres. It is assumed that 80% of the rooftop area can be used for PV. This can accommodate approximately 680 kW DC of solar, which would yield 873,000 kWh in Year 1.

Aligning a roof-mounted solar installation with a new roof is optimal and can prolong the useful life of the roof by preventing UV degradation. For flat roofs, a ballasted racking system can secure panels and limit any penetrations to a single direction service connection from the roof to the electric service panel. Pitched roofs with a standing seam metal roof can utilize racking systems that clamp to the seam, similarly, reducing roof penetration needs to a single direction service connection.

A new installation would be connected to the grid through net-metering where any excess generated energy not used by charging infrastructure or building loads would be sold back to the utility and credited to Milton Transit for future use.

## BATTERY ENERGY STORAGE SYSTEM (BESS)

Energy storage devices can play a critical role within a microgrid or distributed energy resource (DER) system. Although energy storage systems (ESS) are not a generation method, they can provide greater reliability and resiliency for a microgrid, along with potential energy bill reduction applications. They are especially useful when utilizing renewable generation methods, as it can help reduce some of the intermittency issues and extract more value out of those types of assets. Battery energy storage systems (BESS) are the most prominent and mature technology for distributed scale systems and microgrids.

For transit facilities, BESS systems are typically utilized for shifting loads in a strategic way that may help reduce demand charges and total energy costs associated with large charging loads that occur during peak rate hours. The size (kW) and duration (kWh) of a potential BESS is heavily dependent on the available space for installation as size of the system will increase as the nameplate capacity and operational duration increases. BESS size will vary from vendor to vendor, but most solutions are typically of a containerized configuration. Systems of this nature are generally modular and flexible in terms of size with footprints ranging from 2.4 m x 3.7 m upwards to 12 m x 2.4 m (12 m ISO containers).

Agencies that are not subject to a tariff that has time of use charges and those that have access to net-metering may not require BESS since the grid can effectively act as that storage mechanism. Beyond the initial capital cost of purchasing the BESS, they have a usable life and will need to be replaced after operating a certain number of cycles. There are also operating maintenance costs to consider as well as some efficiency losses as energy is put into and taken out of the BESS.

For Milton Transit, the electric vehicle charging system is already designed to manage the demand and keep it at a consistent level throughout the day. This means there are no significant peaks that would benefit from the addition of a BESS. Since the demand profile is relatively flat, there is no need to shift the load, and it is not recommended to use a BESS with the current tariff structure.



## RESILIENCY CONSIDERATIONS

There are a number of technologies and strategies that can be considered at the Milton Transit facility to increase resiliency. Some involve installation of additional infrastructure while others are potential operational strategies that could reduce or mitigate risks which may impact service. These technologies may decline in price, and increase in efficiency, by the time construction commences in 2025-2026. This may include localized generation and battery energy storages systems as described above, along with items such as hydrogen fuel cells, spare buses, or service reductions. Each method provides different levels of support for the fleet and its infrastructure, and their costs to implement should be weight against the need for increased reliability.

While the electric utility will never be able to maintain a system that provides power 100% of the time to every customer, some improvements can increase reliability to an area or a single customer. Milton Transit must balance the operational risk and costs with the resiliency and reliability needs.

## REDUNDANT GRID SOURCES

Depending on the base location another method to increase resiliency is to employ a redundant feeder from the utility grid. Ideally, this secondary redundant source is served by a separate circuit than the primary feeder and could provide power to the transit base in the event the primary source experiences an outage or fault. There are several main grid components that affect the grid source reliability.

## SUBSTATIONS

The electric utility typically takes service from the generation and transmission grid at the utility's substation. The substation converts electricity from a high transmission voltage to the local medium voltage system. Due to land constraints and large load requirements, the local utilities generally operate multiple transformers within each substation and each transformer is connected to multiple medium voltage, distribution feeders. Most outages at the substation level are localized to a single substation transformer. The presence of multiple substation transformers provides redundancy during most normal operations. The utility usually plans maintenance outages to avoid impacting the entire substation; however, when planning for redundant power to the transit base chargers, Milton Transit should request redundant distribution feeders be fed from separate substations if feasible or at the least from separate substation transformers.

## DISTRIBUTION FEEDERS

Medium voltage distribution feeders are installed and operated by the utility to supply electricity to their customers. Utility planners work to ensure that the grid will operate as reliably and efficiently as possible. Utility planners consider how to add new loads to the grid and how to best operate the local grid when maintenance or other outages impact an area or customer. In most cases, impacts to the distribution feeders are seldom known or experienced by the utility customer.

Unexpected outages at the distribution level are often localized and able to be fed from a separate distribution feed. Underground distribution feeder outages are most commonly caused by digging into the line. Underground feeder outages do not happen frequently but occur for a longer duration. To avoid long-duration underground outages, utilities typically operate a loop system that can be switched from one source to another to avoid lengthy delays.





Overhead distribution feeders are installed nearer to the ground than transmission lines, so they are more likely to be impacted by tree branches and animals contacting the bare conductors and shorting the system. Overhead distribution feeders are also not built to the same strength as the transmission lines, so wind and downed trees can also impact these overhead feeders. Overhead feeder outages occur more frequently than underground outages but are repaired much quicker because they are more accessible. Overhead feeders are often configured to allow multiple sources to back feed the line in the event of outage or maintenance.

Some factors for consideration of the distribution feeders may include:

- Whether the charging infrastructure will require a 100% redundant backup source; If 100% redundancy is required, this will increase cost and on-site space required for the utility to provide this level of redundancy.
- Providing separate distribution sources from two separate substations is most desirable but also most costly. If redundant distribution feeds are installed, the Town should consider utilizing sources from separate transformers within that substation.

## INTERNAL COMBUSTION ENGINE (ICE) GENERATION

There are two traditional methods for generating power: combustion turbines and internal combustion engine driven generators. These technologies are both effective for generating power on a large or small scale, whether for primary power generation or backup power. Combustion turbines usually have a higher power output, ranging from 500 kW to 25 MW, but they can also be used to meet larger distributed loads. These machines require hydrocarbon fuel, such as natural gas, oil, or fuel mix, to operate. ICE generators come in a variety of sizes making them highly scalable. These machines have a high degree of reliability and can operate on demand but also require fuel input and maintenance. This provides high degrees of reliability and some resilience, but they may fall short in terms of environmental concerns due to the utilization of fossil fuels.

Using ICE generation to offset BEB charging load is generally not an optimal solution due to high maintenance costs, fuel input, and emissions that make it unsuitable for consistent use. However, these generation methods can still serve as backup power to enable reduced transit operations during electric service outages.

When selecting an ICE generator, footprint is an important consideration. A typical stationary diesel ICE backup generator will require a footprint of approximately 7 m<sup>2</sup>/MW. Therefore, a 1.5 MW stationary backup generator would require approximately 10.5 m<sup>2</sup>, not including ancillary equipment such as transfer switches or noise reduction enclosures.

In addition to stationary ICE generators, there are also portable ICE generators available in a variety of sizes up to about 2 MW. Charging infrastructure at facilities can be designed with capacity to connect portable generators. The benefits of having a portable generator at the depot facility should be considered. This option provides flexibility to relocate the generator as needed, in case of power outages, and eliminates the requirement for separate generators at each site where chargers are installed, including en-route charging





locations. This also allows the option to scale up backup generation in the future by purchasing additional generators if reliability continues to be a challenge.

## HYDROGEN FUEL CELL GENERATIONS

Hydrogen fuel cells can provide a large amount of power in a smaller footprint than other renewable sources and do not suffer from intermittency. Fuel cells also have low to no emissions depending on the fuel utilized but do require fuel input, additional infrastructure, and safety equipment to maintain high temperatures within the device and to safely store potentially volatile fuels.

Historically, fuel cells have relied on hydrogen as their primary fuel source. To use hydrogen fuel cells, a hydrogen fuel source must be available at the intended site. Hydrogen delivery can be accomplished either through on-site or off-site generation. On-site generation requires raw components that are readily available at the site, such as water or natural gas and electricity. The cleanliness of the hydrogen produced is largely determined by the source of the electricity used in the generation process. Renewable sources, such as hydropower, are considered more desirable than coal or hydrocarbon generation. Generating hydrogen on-site requires significantly more infrastructure than the existing facilities can accommodate. On the other hand, if hydrogen is generated off-site, storage tanks and pumps will be required to store and deliver the fuel to the fuel cells. Truck-and-tank delivery systems are typically used for off-site generation since hydrogen pipelines capable of supporting a 1 MW or larger generator are not currently available.

The size, form factor and fuel cell stack deployment are vendor dependent. A 440 kW containerized fuel cell will have a space requirement of 8.5 m x 3.4 m x 2.7 m or an approximate footprint of 0.07 m<sup>2</sup>/kW. The estimated footprint includes only the space required for the fuel cell stacks and does not include the required space for ancillary equipment such as fuel storage or electrolyzers. A 1.5 MW containerized fuel cell installation would utilize 16 units and requires an approximately 100 m<sup>2</sup> footprint.

Similarly, a modular installation would have an approximate space requirement of 4.6 m x 2.7 m x 2.1 m for a 250 kW unit. A 1.5 MW modular installation would require 6 x 250 kW units with an estimated footprint of 100 m<sup>2</sup>. These estimates do not include the necessary space for fuel storage and maintenance access.

In general, fuel cells are not ideal for emergency generator applications where the equipment is stored and operated only for a limited number of hours each year. The reason for this is that fuel cells need to maintain high operating temperatures to function effectively and efficiently. If a fuel cell is cold, it can take up to 10 hours to heat up to the optimal temperature. This long startup time is usually not acceptable for emergency generation applications. One potential solution to this problem is to equip the fuel cell to provide a small portion or the entirety of the full load during normal operation. This way, the fuel cell is always operating and maintains its ability to run during an outage. By operating in this way, the primary and backup power sources can effectively swap roles, so that the electrical grid serves as a backup to the fuel cell, providing the desired level of resiliency. Fuel cells have a very fast ramp rate, which means that they can quickly increase their power output to meet sudden demand. If a fuel cell is kept in hot standby mode and ramped up to full load during an outage, it can provide similar starting characteristics as internal combustion engine (ICE) generators. However, it's important to note that keeping the fuel cell in hot standby mode will require the consumption of natural gas or hydrogen during normal operation.



## REDUCED BUS SERVICE

In the event of an outage, it's important to have a resiliency plan in place that involves reducing the number of bus services that are offered. This can help ensure that the buses are able to maintain a sustainable level of operation, depending on the severity, type, and duration of the outage (whether it's a utility, local, or software issue). Once the outage is resolved and the buses are fully charged, services can be returned to normal levels of operation. Different plans can be developed to optimize services for different outage categories to streamline service reductions. It should be noted that in the event of a large-scale outage, such as those caused by a large natural disaster, the overall demand for transit service will likely decrease as the disaster has larger regional impacts beyond local services. This should be considered if reduced operations plans are developed in the future. Overall, service reduction plans are dependent on the type and scale of an outage and are a viable option as a primary or secondary method of operation resiliency.

## SPARE BUS CAPACITY

Maintaining a fleet of spare buses is also a viable option to sustain a higher percentage of operational transit routes in the event of an outage. This spare fleet would be in addition to the 6% spares that are described in **Table 16** and **Table 35** since these spare buses would largely be reserved for utility outages when additional buses are needed for service. The size of the spare fleet would be dependent on the acceptable/anticipated outage duration and other system reliability factors.

Depending on the type and length of a potential outage, buses can be swapped with fully charged spares from a reserve fleet once they reach a low state of charge. Maintaining a reserve fleet of BEBs would allow Milton Transit to maintain their emissions goals while enabling a greater sense of resiliency for transit operations. However, a reserve fleet of this style is still limited by the charging infrastructure which may be impacted by the potential outage.

A reserve fleet containing diesel buses can provide a greater amount of bus swaps as they are not limited by potential charging outages. While this method may be viable during a phased fleet conversion, this would no longer be viable and considered once the entire fleet becomes battery electric.

While a reserve bus fleet can provide a greater sense of resiliency and allow for increased transit operations during an outage, there are significant costs and space requirements associated with purchasing and maintaining a reserve fleet that should be weighed against the benefits of developing and storing additional vehicles.

## EN-ROUTE/LAYOVER CHARGING

In the event of an outage localized to a transit base, en-route chargers could be utilized to keep transit routes in service. An outage localized at a transit base could affect the charging infrastructure and the charging schedule at the base. As an alternative to significantly reducing transit services, specific routes could be rerouted to utilize en-route charging until the outage at the base is resolved. The duration in which this solution can be utilized for resiliency is dependent on the severity of the outage. Likely, this could be utilized for a short period of time to keep a single day's routes in service without major revision of the transit routes. This would be dependent on the final charging infrastructure design and the location of en-route chargers.



## RESILIENCY RECOMMENDATIONS

Historically, power outages experienced by Milton Transit have been short and infrequent. However, more frequent outages may occur due to extreme temperatures or severe weather events because of global climate change. There are several redundancies that Milton Transit could implement, but in the short-term these will be limited to a reduction of transit bus services and the potential implementation of a diesel backup generator. If the agency experiences a short, isolated outage, Milton Transit may be able to operate the existing service routes with decreased frequency, minimizing the impact reduced service has on riders. In the event of a widespread, prolonged outage, Milton Transit may reduce service to strictly critical operations; this may include the transport of first responders or hospital transport. To support critical operations, Milton Transit will likely need to operate at least 20% of the fleet although this may change depending on service coverage and requirements within the Town's business continuity plans and any commitments to providing transportation during emergencies.

Reduction of services at the beginning of the transition to BEBs would not necessarily require backup power as this service could be supported by the diesel fleet, but alternative redundancies will need to be considered when BEBs make up a larger portion of the fleet. While a backup generator may not be required immediately, it is suggested that the infrastructure be included in the initial phases of the transition to allow for service resiliency. Defining the operational goals and acceptable levels of service during an outage will determine the need and sizing of the infrastructure. There are cost-effective options that Milton Transit can utilize if the grid reliability changes or operational workarounds are insufficient, and a greater number of vehicles must be utilized to maintain critical operations.

Solar PV is being considered as an added improvement to the proposed new Milton Transit Facility. BESS is also considered as part of this study and will be further evaluated during design development via cost-benefit and high-level pros and cons assessment. In the future, Milton Transit may reconsider alternative backup power sources to reach a net-zero carbon footprint with 100% renewable energy.

Milton Transit will continue to evaluate new ways to mitigate the risk of reduced operations through redundancy in power delivery by fueling a portion of the BEB fleet using backup power or by partnering with the utility power provider for a redundant feed. As other municipalities begin planning for transitions to zero emissions and implementing alternative backup or redundant power methods, Milton Transit may opt for the same methods depending on performance and realized risk of outages now and in the future.

## BUILDING CODE AND FIRE SAFETY

Indoor storage of vehicles is not a new concept, but the introduction of BEBs is an aspect that introduces new risks to facilities. Regulatory authorities are still working to determine if additional requirements will be needed. The biggest change with the introduction of BEBs and charging infrastructure is the increase in high voltage electrical equipment that is now being installed as well as the possibility of lithium-ion battery fires from vehicles stored inside facilities.

Each province and territory in Canada has its own building code, which may adopt the National Building Code of Canada (NBCC) or modify it to suit local requirements. These codes may include specific provisions related to fire safety in buildings that house BEBs or other hazardous materials. While the NBCC does not



specifically address battery electric vehicles currently, it sets standards for fire safety, electrical systems, ventilation, and other aspects that would apply to any building.

The Canadian Electric Code (CEC) is a national standard for electrical installations in Canada. It provides requirements for the safe installation and use of electrical equipment, including charging stations for BEBs. Electrical codes are already in place that dictate measures that would be required for installation of high voltage electrical equipment and their required safety devices. Electrical designs will need to be done by qualified professionals and will be reviewed through the building permit process to ensure the designs meet relevant electrical code requirements.

Fire safety standards for BEBs are an emerging area and some codes have not yet caught up to determine what the requirements should be for facilities that house BEVs. Vehicle fires are not a new concept for buildings and while, to date, battery electric vehicle fires are statistically less common than internal combustion vehicles, they do happen and behave differently. For example, if thermal runaway occurs in a battery pack, the fire can be difficult to extinguish, may take hours to put out, and has the potential to reignite. While insurance rate premiums have not yet increased due to battery electric bus fires, that potential exists, and premiums may increase if bus fires increase. It is anticipated that the bus and charger manufacturers will continue to improve their battery monitoring, fire suppression, and overall safety to avoid harming public and operators as well as to avoid costly recourse such as vehicle recalls and lawsuits.

Fleet operators have been proactive in thinking about how to mitigate these risks and while the current building codes may not explicitly dictate requirements, there are suggestions that can be provided based on experience as to what transit agencies should consider in terms of additional fire safety measures:

- Develop a fire safety plan with the local fire department that addresses how to deal with a fire.
- Performing a facility fire safety risk assessment to evaluate aspects such as:
  - Rating of the building fire suppression system in vehicle storage areas.
  - Availability of water for the fire department to be able to extinguish fires.
  - Emergency power shut offs for charging equipment.
  - Manual HVAC controls to exhaust smoke and fumes from a vehicle fire.
- Having an ongoing dialogue with first responders after implementation so that first responders are familiar with the facility, vehicles, and tools available to deal with fires at the facility.



## APPENDIX C: BUDGET & FINANCIAL PLAN

This appendix breaks down all details of the financial analysis, including assumptions, model results, and supplementary tables for cost breakdowns over the whole analysis period.

### FLEET TRANSITION SCENARIOS

The financial analysis considers two scenarios for Milton Transit's fleet transition. Each scenario evaluates the capital, operating, maintenance, and fuel/electricity costs over the 2023-2050 period. The assumptions used are detailed further below. The two scenarios evaluated reflect the following:

- **Baseline (Business as Usual) Scenario:** Reflects the scenario where no transition to BEBs occurs. All replacements of the current diesel fleet are with new diesel buses. Specialized 6m and 8m vehicles are replaced with new gas-powered vehicles.
- **BEB Transition Scenario:** This scenario reflects the full transition of Milton Transit's fleet to 675 kWh BEBs, and in-depot charging only as part of a phased transition beginning in 2024. Specialized 6m and 8m fleet vehicles are replaced with BEV equivalents.

### LIFECYCLE COST ANALYSIS

The lifecycle cost analysis compares the lifecycle cost of implementing each scenario described above. The analysis includes the cost of purchasing buses and related infrastructure, ongoing O&M costs, and fuel and electricity costs.

### KEY COST ASSUMPTIONS

The analysis relies on several assumptions like bus operating statistics and purchasing schedules for the Baseline and BEB Scenarios. Capital costs include vehicle purchase costs, BEB charging infrastructure costs, annual cost of transfers to reserve for equipment replacement, and any required electric utility service upgrades.

The projections in this analysis are based on numerous assumptions using the best available data. However, there are several "known-unknowns" in the analysis that have not been quantified. For completeness, they are listed here to reflect that projections may vary from the forecasts used in this analysis.

- **BEB prices:** BEB prices may fall over the near-medium term as technology advances. This analysis uses current pricing and does not factor in the potential for price parity with diesel buses.
- **Vehicle charger service life:** the service life of charging infrastructure is an unknown because there is not data available on the average service life based on actual performance. A 12-year service life is assumed for transfer to reserve costs, but the annual maintenance costs is intended to capture the annualized replacement cost of a charger.
- **Labor and staffing costs:** the precise quantity and type of staffing and training needed will vary based on the precise fleet needs, who performs the training, and when it occurs. As a result, it is not quantified in this analysis.
- **Insurance costs:** due to the higher electricity demand and BEBs to be used at Milton Transit facility, the Town noted potential increased insurance costs. These are noted as an unknown in this analysis and not quantified.



## VEHICLE CAPITAL COSTS

**Table 32.** Capital Cost Assumptions, 2023\$ presents the unit cost assumptions for conventional and battery electric buses and specialized transit vehicles. These include the purchase costs and mid-life rehabilitation costs.

**Table 32. Capital Cost Assumptions, 2023\$**

Capital Assumptions	
Diesel Bus Cost	\$915,024
Battery Electric Bus Cost (675 kWh)	\$1,909,686
Repowering Cost	\$600,000
6m Specialized Transit (ICE)	\$218,473
6m Specialized Transit (BEB)	\$393,319
8m Specialized Transit (ICE)	\$258,888
8m Specialized Transit (BEB)	\$462,843
Diesel Bus Midlife Rehabilitation Cost	\$120,300
BEB Midlife Rehabilitation Cost	\$7,000

## INFRASTRUCTURE CAPITAL COSTS

**Table 33** identifies the capital costs associated with charging infrastructure required for BEVs listed in the replacement schedule. As noted in the fleet modelling analysis, the Milton Transit Facility has been designed to phase in additional infrastructure primarily including substations, 150 kW charging equipment, circuit breakers, and other infrastructure needed to facilitate charging for the BEB fleet. Costs are presented in 2023 dollars, similar to other capital costs modelled.

**Table 33. Infrastructure Unit Cost Assumptions, 2023\$**

Infrastructure	Unit Cost
Plug-In Depot Charger Cabinet (150 kW)	\$154,097
Plug-In Depot Charger Wall-Mounted Dispenser	\$25,265
Plug-In Depot Charger Overhead Reel Dispenser	\$32,158

## OPERATING AND MAINTENANCE COST ASSUMPTIONS

Ongoing operating and maintenance (O&M) costs for Milton Transit’s conventional diesel fleet and their modelled BEB replacements are part of this analysis.

- **Bus Operations:** The operating cost per hour was based on Milton Transit’s submission to CUTA 2021 Conventional Transit Statistics. The total cost of operations was inflated to 2023 dollars, then divided by total vehicle hours. This cost is applied to total estimated operating hours for diesels and BEBs throughout the transition plan.
- **Bus Maintenance:** The maintenance cost per kilometre for diesel buses was calculated based on Milton Transit’s submission to CUTA 2021 Conventional Transit Statistics. The total maintenance cost was inflated to 2023 dollars, then divided by total vehicle kilometres. A literature review of



maintenance costs for BEBs identified a range of 10%-30% cost savings relative to diesel, primarily due to fewer part replacements and simpler drivetrain maintenance. For BEB annual maintenance costs, a 10% cost savings assumption was applied to remain conservative. This is based on the Argonne National Laboratory’s Total Cost of Ownership study completed in 2021.<sup>12</sup>

- **Fuel Efficiency:** Litres per 100 kilometres (L/100km) was calculated as an average of the diesel consumption divided by total vehicle kilometres travelled recorded by Milton Transit reported in CUTA 2021 Conventional Transit Statistics.<sup>13</sup>
- **Maintenance of BEB Charging Equipment:** Costs shown in reflect annualized maintenance cost values from a service level agreement for a charger representative of proposed EV charging equipment.

## OPERATING COST ASSUMPTIONS

The cost of labor in both scenarios is based on the anticipated operating hours in both scenarios. The cost per hour is assumed to be the same, but the total cost in the BEB Transition Scenario is greater due to an increase in non-revenue hours to deadhead to and from the garage. Fuel efficiency, spare ratio, and other KPIs are not impacted by reduced services to COVID in 2021. Pre-COVID GTFS data was used in the vehicle modelling and is reflected in operating statistics used in the financial analysis.

**Table 34. Unit Operating Cost, 2023\$**

	2023\$
Operating Cost (\$/hour)	\$98.59

<sup>12</sup> [Comprehensive Total Cost of Ownership Quantification for Vehicles with Different Size Classes and Powertrains \(anl.gov\)](#)

<sup>13</sup> Fuel efficiency rates and KPIs are not impacted by reduced transit service due to COVID in 2021.



**Table 35. Annual Operating and Maintenance Cost Assumptions (2023\$)**

Conventional Fleet Operating Assumptions	Diesel	BEB
<b>Operating Costs (\$/hr)</b>	\$98.59	\$98.59
<b>Maintenance Cost (\$/km)</b>	\$0.64	\$0.58
<b>BEB Maintenance Cost Efficiency Factor</b>	-	10%
<b>Charger Efficiency</b>	-	95%
<b>Charger Maintenance Cost (\$/year)</b>	-	\$5,959
<b>Average Useful Life of New Bus</b>	12	12
<b>Bus Fuel Efficiency (L/100 km)</b>	46.1	-
<b>Diesel Heater Efficiency (L/km)</b>	-	0.034
<b>Spare Bus Ratio (Peak Fleet/Total Fleet)</b>	6%	6%
<b>Fixed Route Transfer to Reserve (\$/year)</b>	\$76,252	\$159,140

## FUELING COST ASSUMPTIONS

Estimated annual diesel fuel and electricity reflect a combination of growth rate assumptions. Additionally, the following assumptions and sources were used to estimate projected change in cost of diesel and electricity.

### DIESEL AND GASOLINE FUEL COSTS

The analysis assumed diesel fuel costs in 2023 are \$1.49 per litre, as identified in the 2024 Budget. The analysis assumes that gasoline fuel costs in 2023 are \$1.46 per litre as identified in Milton’s 2024 Budget. The wholesale prices had provincial and federal taxes layered on, including the unrecoverable net HST. Wholesale fuel costs were assumed to remain constant. The carbon tax was assumed to escalate in line with the latest federal carbon pricing plan, while other provincial and federal taxes were assumed to remain constant for the duration of the analysis. All BEBs were assumed to have diesel heaters to ensure electric power can focus on maintaining maximum driving range. The average fuel efficiency of diesel heaters was obtained based on industry experience to estimate the diesel usage per kilometre travelled.

**Table 36. Diesel and Gasoline Unit Cost Assumptions, 2023\$**

	2023	2025	2030	2035	2040	2045	2050
<b>Diesel Cost (\$/Litre)</b>	\$1.49	\$1.49	\$1.49	\$1.49	\$1.49	\$1.49	\$1.49
<b>Gasoline Cost (\$/Litre)</b>	\$1.46	\$1.46	\$1.46	\$1.46	\$1.46	\$1.46	\$1.46
<b>Diesel Carbon Levy (\$/Litre)</b>	\$0.17	\$0.25	\$0.45	\$0.45	\$0.45	\$0.45	\$0.45
<b>Gasoline Carbon Levy (\$/Litre)</b>	\$0.14	\$0.21	\$0.37	\$0.37	\$0.37	\$0.37	\$0.37

### ELECTRICITY COSTS

Electricity costs are included in the analysis were based on a per kilowatt-hour (kWh) usage fee. The values used in the analysis were determined from published rates available from Milton Hydro. The dollar per kWh





(\$/kWh) usage fee was based on the weighted average cost per kWh from Milton Hydro and the Global Adjustment Factor for 2023. The analysis assumes a 5% efficiency loss between chargers and BEBs.

**Table 37. Electricity Unit Cost Assumptions, 2023\$**

	2023
Electricity Price (\$/kWh)	\$0.20
Demand Charge (\$/kW)	\$11.67

## MAINTENANCE COST ASSUMPTIONS

A literature review of maintenance costs for BEBs identified a range of 10%-30% cost savings relative to diesel, primarily due to fewer part replacements and simpler drivetrain maintenance. For BEB annual maintenance costs, a 10% cost savings assumption was applied to remain conservative.

**Table 38. Maintenance Cost Unit Assumptions, 2023\$**

	2023
Diesel Maintenance Cost (\$/km)	\$0.64
BEB Maintenance Cost (\$/km)	\$0.58

## SPECIALIZED FLEET ASSUMPTIONS

In addition to the conventional fleet, Milton Transit also operates a specialized fleet, currently containing 8m and 6m ICE vehicles. 8m and 6m vehicle capital and operating expenses are presented separately from the conventional fleet. 8m and 6m vehicle operating statistics were calculated from Milton Transit data for 2022. The average daily kilometres driven, hours utilized, and assumed utilization were combined to calculate the operating statistics for the fleet on an annual basis. The 8m specialized fleet is expected to remain at 8 vehicles. The 6m specialized fleet is expected to grow from 8 vehicles to 15 vehicles to meet future service needs. **Table 39** shows the operating assumptions for the specialized transit fleet.



**Table 39. On-Demand Fleet Operating and Maintenance Cost Assumptions, 2023\$**

Non-Conventional Fleet Operating Assumptions	Diesel/Gasoline	BEB
<b>Maintenance Cost (\$/km)</b>	\$0.61	\$0.55
<b>8m Fuel Efficiency (L/100 km)</b>	41.0	-
<b>6m Fuel Efficiency (L/100 km)</b>	31.9	-
<b>Average BEB:Diesel Transition Ratio</b>	-	1.00
<b>Daily Energy Usage per 6m Vehicles (kWh)</b>	-	76.9
<b>Daily Energy Usage per 8m Vehicles (kWh)</b>	-	88.6
<b>Average Useful Life of Specialized Vehicles (years)</b>	7	8
<b>8m Average Daily Kilometres Driven</b>	177	177
<b>6m Average Daily Kilometres Driven</b>	147	147
<b>8m Average Daily Hours Utilized</b>	10	10
<b>6m Average Daily Hours Utilized</b>	10	10
<b>8m Specialized Transfer to Reserve (\$/year)</b>	\$36,984	\$57,855
<b>6m Specialized Transfer to Reserve (\$/year)</b>	\$31,210	\$49,165

## BASELINE SCENARIO

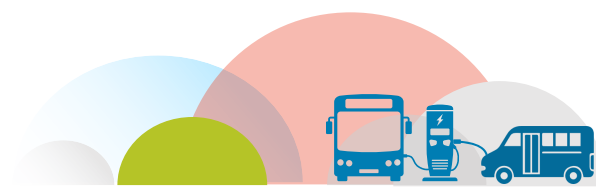
The Baseline Scenario is defined as where there is no transition to electric vehicles over the study period. As described above, the Baseline Scenario refers to the current diesel fleet being replaced strictly by new diesel buses in alignment with the current fleet retirement schedule. **Table 40** below shows the annual total number of hours and kilometres operated by the diesel fleet; this service level is assumed to grow from 2023 through 2040 in the Baseline Scenario. While there is expected to be service growth from 2041-2050, this is assumed to be flat in the analysis due to uncertainty about the timing and quantity of future fleet expansion.

**Table 40. Baseline Scenario Annual Service Levels**

	2023	2025	2030	2035	2040	2045	2050
<b>Kilometres Travelled</b>	1,222,080	1,222,080	2,749,680	3,360,721	3,360,721	3,360,721	3,360,721
<b>Hours of Operation</b>	53,034	53,034	119,327	145,844	145,844	145,844	145,844
<b>Litres of Fuel Consumed</b>	563,785	563,785	1,268,516	1,550,408	1,550,408	1,550,408	1,550,408

## BASELINE CAPITAL COST ESTIMATES

Under the Baseline Scenario, the fleet mix remains entirely diesel and gasoline vehicles for the duration of the study period. Milton Transit’s fleet retirement schedule as of November 2022 was used to determine the capital purchases needed each year. **Table 41** illustrates the near-, mid-, and long-term total number of replacement ICEVs purchased based on the fleet retirement schedule. These vehicle purchases also assume that some vehicles are replaced more than once between now and 2050, thus a total that is larger than the 45 vehicles.



**Table 41. Baseline Scenario Periodic Capital Purchases Assumptions Based on the Fleet Retirement Schedule**

	Replacement			Growth			Total		
	Phase 2A	Phase 2B	Phase 3	Phase 2A	Phase 2B	Phase 3	Phase 2A	Phase 2B	Phase 3
	2025-2028	2029-2030	2031-2040	2025-2028	2029-2030	2031-2040	2025-2028	2029-2030	2031-2040
<b>Baseline Scenario</b>									
<b>Bus – 12M</b>	-	7	12	16	3	25	16	10	37

**Table 42** presents the annual costs estimates based on the unit cost and growth rate assumptions and the annual fleet needs shown in **Table 41** above. The values are in 2023 dollars.

**Table 42. Annual Capital Cost Estimates, Selected years, 2023\$, Millions**

	Replacement			Growth			Total		
	Phase 2A	Phase 2B	Phase 3	Phase 2A	Phase 2B	Phase 3	Phase 2A	Phase 2B	Phase 3
	2025-2028	2029-2030	2031-2040	2025-2028	2029-2030	2031-2040	2025-2028	2029-2030	2031-2040
<b>Baseline Scenario</b>									
<b>Bus – 12M</b>	-	\$6.4	\$11.0	\$14.6	\$2.7	\$22.9	\$14.6	\$9.2	\$33.9
<b>Bus – 6M</b>	\$1.3	\$0.4	\$4.4	\$0.7	\$0.4	\$0.9	\$2.0	\$0.9	\$5.2
<b>Bus – 8M</b>	\$0.5	\$1.0	\$1.6	-	-	-	\$0.5	\$1.0	\$1.6

## BASELINE OPERATING COST ESTIMATES

The annual operating costs between 2023 and 2050 are calculated by multiplying the hours of operation by the estimated hourly operating cost. presents the near-, mid-, and long-term total periodic operating costs under the Baseline Scenario.

**Table 43. Baseline Scenario Periodic Operating Cost Estimates, 2023\$, Millions**

	2023 - 2030	2031 - 2040	2041 - 2050
<b>Operating Costs</b>	\$64.1	\$138.6	\$143.8

## BASELINE MAINTENANCE COST ESTIMATES

The annual maintenance costs between 2023 and 2050 are calculated by multiplying the kilometres travelled by the estimated per kilometre maintenance cost. presents the near-, mid-, and long-term total periodic operating costs under the Baseline Scenario.



**Table 44. Baseline Scenario Periodic Maintenance Costs Estimates, 2023\$, Millions**

	2023 - 2030	2031 - 2040	2041 - 2050
<b>Maintenance Costs</b>	\$13.0	\$26.7	\$28.2

## BASELINE FUELING COST ESTIMATES

Under the Baseline Scenario, the only fuel required to operate the fleet is diesel. The annual diesel fuel costs were calculated based on the annual kilometres travelled, the average fuel economy, and the cost of diesel. The estimated diesel fuel consumed by buses was calculated by multiplying the average fuel economy from Milton fleet data and the total kilometres travelled. The litres of fuel were then multiplied by the average price per litre of diesel detailed in the O&M Cost Assumptions section above. The diesel cost calculation is shown in **Table 45** below.

**Table 45. Baseline Scenario Periodic Diesel Costs, 2023\$, Millions**

	2023 - 2030	2031 - 2040	2041 - 2050
<b>Diesel Fuel Costs</b>	\$10.3	\$22.3	\$23.1

## BASELINE SPECIALIZED TRANSIT FLEET COSTS

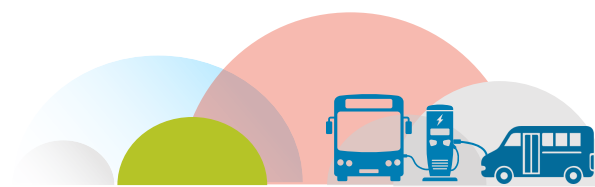
Milton Transit currently operates a specialized transit fleet with gasoline and diesel buses. Under the Baseline Scenario, it was assumed there is no transition to electric vehicles over the study period. The current paratransit fleet will be replaced by new gasoline buses on an as-needed basis. Capital purchases for the specialized fleet was based on the projected retirement of existing vehicles and the future service expansion plan.

**Table 46** summarizes the capital purchase plan of paratransit vehicles for selected years.

**Table 46. Specialized Fleet Periodic Total Capital Purchases**

	Replacement			Growth			Total		
	Phase 2A	Phase 2B	Phase 3	Phase 2A	Phase 2B	Phase 3	Phase 2A	Phase 2B	Phase 3
	2025-2028	2029-2030	2031-2040	2025-2028	2029-2030	2031-2040	2025-2028	2029-2030	2031-2040
<b>Baseline Scenario</b>									
<b>Bus – 6M</b>	6	2	20	3	2	4	9	4	24
<b>Bus – 8M</b>	2	4	6	-	-	-	2	4	6

**Table 47** displays the costs associated with the purchase schedule of specialized gas vehicles in **Table 45**.



**Table 47. Baseline Scenario Specialized Transit Periodic Capital Cost Estimates, 2023\$, Millions**

		Replacement				Growth			Total	
	Phase 2A	Phase 2B	Phase 3	Phase 2A	Phase 2B	Phase 3	Phase 2A	Phase 2B	Phase 3	
	2025-2028	2029-2030	2031-2040	2025-2028	2029-2030	2031-2040	2025-2028	2029-2030	2031-2040	
<b>Baseline Scenario</b>										
<b>Bus – 6M</b>		\$1.3	\$0.4	\$4.4	\$0.7	\$0.4	\$0.9	\$2.0	\$0.9	\$5.2
<b>Bus – 8M</b>	\$0.5	\$1.0	\$1.6	-	-	-	\$0.5	\$1.0	\$1.6	

**Table 48** contains the annual maintenance costs for the specialized vehicles.

**Table 48. Baseline Scenario Periodic Operations & Maintenance Costs, 2023\$, Millions**

	2023 - 2030	2031 - 2040	2041 - 2050
<b>Annual Maintenance Cost</b>	\$3.4	\$5.9	\$6.6

**Table 49** summarizes the annual fuel costs for the baseline scenario for selected years over the 2023 to 2050 period.

**Table 49. Baseline Scenario Periodic Total Fuel Costs, 2023\$, Millions**

	2023 - 2030	2031 - 2040	2041 - 2050
<b>Average Unit Cost of Gasoline<sup>14</sup></b>	\$1.46	\$1.46	\$1.46
<b>Cost of Gasoline (\$millions)</b>	\$2.4	\$4.9	\$5.4
<b>Gasoline Fuel Carbon Tax (\$millions)</b>	\$0.5	\$1.3	\$1.4
<b>Total Cost of Fuel</b>	\$2.9	\$6.2	\$6.8

## BASELINE SUMMARY

Under the Baseline Scenario, the total cost of implementation was estimated to be \$692.7 million in 2023 dollars. The total capital costs are \$209.6 million. Total lifecycle O&M costs of \$483.1 million include operations, maintenance, and propulsion costs. The full results of the Baseline scenario are shown in **Table 50** below.

<sup>14</sup> Average cost of gasoline in first year of year excerpt



**Table 50. Baseline Scenario Summary, 2023\$, Millions, 2023-2050**

2023\$, Millions	Baseline
Buses	\$108.0
Midlife Rehabilitation	\$81.4
Specialized Transit	\$20.2
Related Infrastructure	-
<b>Lifecycle Capital Costs, Total</b>	<b>\$209.6</b>
Operations & Maintenance	\$398.4
Propulsion	\$55.7
Related Infrastructure O&M	-
<b>Lifecycle O&amp;M, Fixed Route</b>	<b>\$454.1</b>
Operations & Maintenance	\$15.8
Propulsion	\$13.2
<b>Lifecycle O&amp;M, Specialized Transit</b>	<b>\$29.0</b>
<b>Total Lifecycle Costs, Entire Fleet</b>	<b>\$692.7</b>

## BEB TRANSITION SCENARIO

As described above, the BEB Transition Scenario refers to the current diesel fleet being replaced with BEBs in alignment with the current fleet retirement schedule. In the model, blocks are converted from diesel to electric buses using a two-step prioritization method. Blocks are prioritized first if they can be converted on a one-to-one basis (diesel to BEB) without the need for en-route charging infrastructure. After the initial conversion, BEBs are reprioritized based on blocks that can be converted on a one-to-one basis with the greatest total kilometres travelled.

**Table 51** below shows the incremental annual total number of hours, kilometres, litres of diesel, and kWh of electricity operated and consumed by the fleet; as diesel buses are phased out and BEBs are introduced into the fleet, the total operating hours and kilometres increases due to an increase in non-revenue hours and miles, impacting costs and fuel consumption. In later years of the transition, diesel consumption is attributed solely to diesel auxiliary heaters equipped on the BEBs.

**Table 51. BEB Transition Scenario Annual Service Levels**

	2023	2025	2030	2035	2040	2045	2050
<b>Diesel</b>							
<b>Kilometres</b>	1,222,080	1,222,080	2,142,465	1,412,991	152,760	-	-
Hours	53,034	53,034	92,893	62,878	6,629	-	-
<b>Litres of Diesel</b>	563,785	563,785	1,010,538	719,711	181,731	116,546	116,546
<b>BEB</b>							
<b>Kilometres</b>	-	-	646,590	1,980,741	3,247,809	3,402,182	3,402,182
Hours	-	-	27,312	82,752	137,085	143,520	143,520
<b>kWh</b>	-	-	1,071,532	3,256,665	5,372,031	5,625,623	5,625,623



## BEB TRANSITION CAPITAL COST ESTIMATES

The focus for the BEB Scenario is the financial impact of the changes in fleet mix and associated capital infrastructure and service plans over the 2023 to 2050 period.

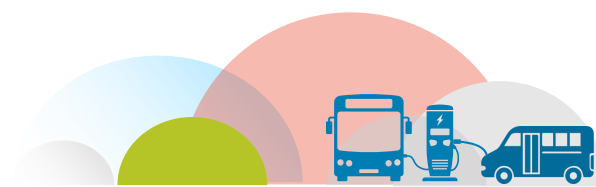
**Table 52** illustrates the near-, mid-, and long-term total number of vehicles and chargers purchased based on the fleet retirement schedule. These vehicle purchases also assume that some vehicles are replaced more than once between now and 2050, thus a total that is greater than 45 buses.

**Table 52. BEB Scenario Periodic Capital Purchase Assumptions**

	Replacement			Growth			Total		
	Phase 2A	Phase 2B	Phase 3	Phase 2A	Phase 2B	Phase 3	Phase 2A	Phase 2B	Phase 3
	2025-2028	2029-2030	2031-2040	2025-2028	2029-2030	2031-2040	2025-2028	2029-2030	2031-2040
<b>BEB Transition Scenario – Diesel/Gasoline</b>									
Bus – 12M	-	-	-	8	-	-	8	-	-
Bus – 6M	3	-	-	2	-	-	5	-	-
Bus – 8M	1	-	-	-	-	-	1	-	-
<b>BEB Transition Scenario – Battery Electric</b>									
BEB – 12M	-	6	11	8	3	25	8	9	36
BEB – 6M	3	2	20	1	2	4	4	4	24
BEB – 8M	1	4	6	-	-	-	1	4	6

BEBs were assumed to be purchased two years prior to entering service. Once BEBs can no longer replace a diesel bus on a one-to-one basis without enroute chargers, we assumed additional BEBs are purchased to cover routes with bus swaps. As noted in the Key Cost Assumptions section above, 1 diesel bus is converted (“repowered”) to a BEB halfway through its service life. Diesel purchases along with BEBs are made through 2029, after which only BEB vehicles are purchased.

**Table 53** presents the annual costs estimates based on the unit cost assumptions and the annual capital needs.



**Table 53. BEB Scenario Periodic Total Capital Cost Estimates, 2023\$, millions**

	Replacement			Growth			Total		
	Phase 2A	Phase 2B	Phase 3	Phase 2A	Phase 2B	Phase 3	Phase 2A	Phase 2B	Phase 3
	2025-2028	2029-2030	2031-2038	2025-2028	2029-2038	2031-2040	2025-2028	2029-2030	2031-2038
<b>BEB Transition Scenario – Diesel/Gasoline</b>									
Bus – 12M	-	-	-	\$7.3	-	-	\$7.3	-	-
Bus – 6M	\$0.7	-	-	\$0.4	-	-	\$1.1	-	-
Bus – 8M	\$0.3	-	-	-	-	-	\$0.3	-	-
<b>BEB Transition Scenario – Battery Electric</b>									
BEB – 12M	-	\$11.5	\$21.0	\$15.3	\$5.7	\$47.7	\$15.3	\$17	\$69
BEB – 6M	\$1.2	\$0.8	\$7.9	\$0.4	\$0.8	\$1.6	\$1.6	\$1.6	\$9.4
BEB – 8M	\$0.5	\$1.9	\$2.8	-	-	-	\$0.5	\$1.9	\$2.8
<b>Charging Infrastructure Cost</b>									
Infrastructure	\$10.3	\$3.7	\$17.8	-	-	-	\$10.3	\$3.7	\$17.8

In addition to the cost of vehicles and chargers, lump sum phasing costs shown in **Table 54** include budgetary pricing provided by electrical infrastructure OEMs for unit substations, and typical unit costs for other civil and electrical work (conduits, grounding, patching), and other anticipated construction expenses. The per-phase costs also factor in a 4% engineering design and a 20% contingency based on concept plan details.

**Table 54. Infrastructure Phasing Assumptions, 2023\$**

Phase	Cost	Purchase Year	Key Equipment
<b>Phase 1</b>	\$7,472,500	2025	2667 kVA unit substation (#1), initial deployment of chargers as shown in the phasing plan and concept figures.
<b>Phase 2A</b>	\$2,827,400	2025-2028	Expansion of DCFC and Level 2 charging infrastructure.
<b>Phase 2B</b>	\$3,748,000	2029-2030	2667 kVA unit substation, Eighteen (18) 150 kW wall-mounted plug-in dispensers, thirteen (13) 7.2 kW specialized transit chargers
<b>Phase 3</b>	\$17,785,500	2031-2038	2667 kVA unit substation (#2), ultimate deployment of chargers as shown in the phasing plan and concept figures.

Over the 2023 to 2050 period, total capital costs for the BEB Scenario were estimated to be \$273.6 million in 2023 dollars. As shown on the previous figures and tables, the bulk of the BEB fleet transition would occur between 2025 and 2035, with the remaining diesel buses in service replaced by BEBs by 2041. To accommodate the BEB fleet, a total of forty-five (45) 150 kW in-depot dispensers will be acquired between 2024 and 2032.

## BEB TRANSITION OPERATING COST ESTIMATES

In the model, blocks were converted from diesel to electric buses using a two-step prioritization method. Blocks were prioritized first if they can be converted on a one-to-one basis (diesel to BEB) without the need





for enroute charging infrastructure. After the initial conversion, BEBs were reprioritized based on blocks that can be converted on a one-for-one basis with the greatest total kilometres travelled.

**Table 55** summarizes the annual vehicle operating costs and annual transfers to reserves for replacement between 2023 and 2050. As noted above, by 2042 the entire fleet has been transitioned to BEBs.

**Table 55. BEB Scenario Periodic Total Operating Cost Estimates, 2023\$, millions**

	2023 - 2030	2031 - 2040	2041 - 2050
Diesel Operating Costs	\$54.6	\$48.0	\$0.3
BEB Operating Costs	\$10.0	\$89.9	\$141.2
Diesel Bus Transfers to Reserve	-	-	-
BEB Transfers to Reserve	\$11.6	\$60.2	\$74.5
Electrical Infrastructure Transfer to Reserve	\$2.3	\$3.7	\$2.3
<b>Total</b>	<b>\$78.5</b>	<b>\$201.8</b>	<b>\$218.3</b>

## BEB FUELING COST ESTIMATES

Based on the methodology described in O&M Cost Assumptions, summarizes the fuel and electricity cost estimates for the BEB scenario for selected years over the 2023 to 2050 period. These costs were estimated to be \$19.4 million for diesel and \$21.7 million in 2023 dollar terms for electricity. Diesel fuel consumption in the latter years of the study period is from the auxiliary heaters on board BEBs.

**Table 56. BEB Transition Scenario Fuel and Electricity Annual Usage**

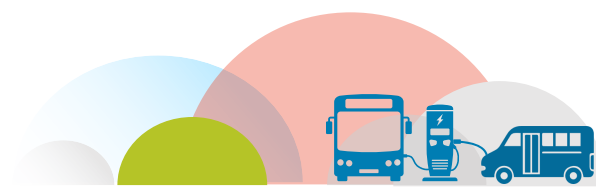
	2023	2025	2030	2035	2040	2045	2050
Litres of Diesel	563,785	563,785	1,010,538	719,711	181,731	116,546	116,546
kWh	-	-	1,071,532	3,256,665	5,372,031	5,625,623	5,625,623

**Table 57. BEB Scenario Periodic Total Fuel and Electricity Cost Estimates, 2023 \$, Millions**

	2023 - 2030	2031 - 2040	2041 - 2050
Diesel Fuel Costs	\$6.9	\$6.0	\$1.2
Electricity Costs	\$0.8	\$8.2	\$12.7
Carbon Levy Costs	\$2.0	\$2.7	\$0.5
<b>Total Fueling Costs</b>	<b>\$9.7</b>	<b>\$16.9</b>	<b>\$14.5</b>

## BEB TRANSITION MAINTENANCE COST ESTIMATES

**Table 58** summarizes the annual vehicle maintenance costs, mid-life rehabilitation costs, and the annual EV chargers' maintenance costs between 2023 and 2050. As noted above, by 2041 the entire fleet has been transitioned to BEBs.



**Table 58. BEB Scenario Periodic Total Operating Cost Estimates, 2023 \$, Millions**

	2023 - 2030	2031 - 2040	2041 - 2050
<b>Diesel Maintenance Costs</b>	\$8.4	\$7.7	\$0.05
<b>BEB Maintenance Costs</b>	\$8.7	\$85.8	\$141.2
<b>Related Infrastructure Maintenance</b>	\$0.04	\$0.5	\$0.9
<b>Total</b>	<b>\$17.2</b>	<b>\$94.0</b>	<b>\$142.1</b>

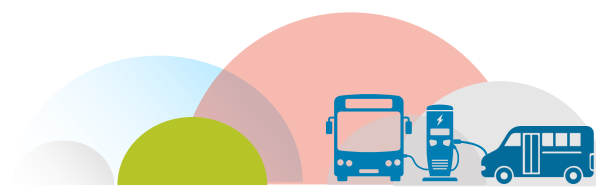
### BEB TRANSITION SPECIALIZED TRANSIT FLEET COSTS

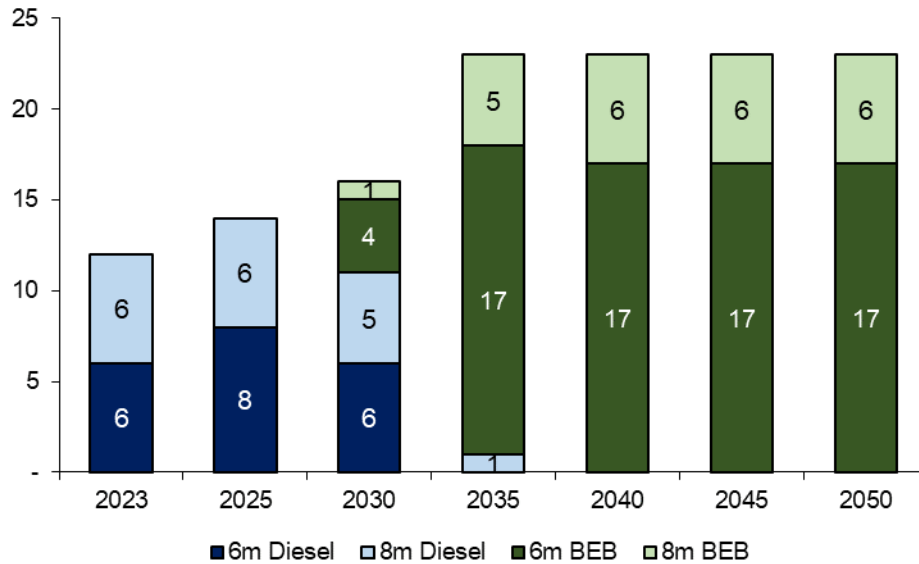
Milton Transit offers specialized and on-demand transit services along with its fixed route fleet. Capital purchases of 6m and 8m “Specialized” vehicles based on the projected retirement of existing vehicles and planned introduction of new vehicles are shown in **Table 59**. The totals include purchases of replacements in future years, so the total purchases exceed the 23 vehicles of the expanded fleet.

**Table 59. BEB Scenario Periodic Specialized Transit Capital Purchases**

	Replacement			Growth			Total		
	Phase 2A	Phase 2B	Phase 3	Phase 2A	Phase 2B	Phase 3	Phase 2A	Phase 2B	Phase 3
	2025-2028	2029-2030	2031-2040	2025-2028	2029-2030	2031-2040	2025-2028	2029-2030	2031-2040
<b>BEB Transition Scenario – Diesel/Gasoline</b>									
<b>Bus – 6M</b>	3	-	-	2	-	-	5	-	-
<b>Bus – 8M</b>	1	-	-	-	-	-	1	-	-
<b>BEB Transition Scenario – Battery Electric</b>									
<b>BEB – 6M</b>	3	2	20	1	2	4	4	4	24
<b>BEB – 8M</b>	1	4	6	-	-	-	1	4	6

**Figure 27** below displays the specialized fleet composition by vehicle type for selected years in the study period. Based on the planned retirement of current diesel vehicles, the entire baseline fleet is expected to be converted by 2033. There is one growth 6m ICEV that is purchased during Phase 2A, which remains in service until 2035. This chart is constructed based on the purchase schedule outlined above and in the Fleet Deployment Plan. The chart accounts for the two year lag between purchase and entering service.





**Figure 27. Specialized Fleet Composition, Selected Years**

**Table 60** displays the costs associated with the purchase of specialized transit vehicles.

**Table 60. Specialized Transit Capital Costs, 2023\$ Millions**

	Replacement			Growth			Total		
	Phase 2A	Phase 2B	Phase 3	Phase 2A	Phase 2B	Phase 3	Phase 2A	Phase 2B	Phase 3
	2025-2028	2029-2030	2031-2040	2025-2028	2029-2030	2031-2040	2025-2028	2029-2030	2031-2040
<b>BEB Transition Scenario – Diesel/Gasoline</b>									
Bus – 6M	\$0.7	-	-	\$0.4	-	-	\$1.1	-	-
Bus – 8M	\$0.3	-	-	-	-	-	\$0.3	-	-
<b>BEB Transition Scenario – Battery Electric</b>									
BEB – 6M	\$1.2	\$0.8	\$7.9	\$0.4	\$0.8	\$1.6	\$1.6	\$1.6	\$9.4
BEB – 8M	\$0.5	\$1.9	\$2.8	-	-	-	\$0.5	\$1.9	\$2.8

**Table 61** below contains annual cost estimates for O&M for the specialized transit fleet in 2023\$.

**Table 61. BEB Scenario Periodic Specialized Fleet Maintenance Costs, 2023\$, Millions**

	2023 - 2030	2031 - 2040	2041 - 2050
Specialized ICE O&M	\$3.0	\$0.4	-
Specialized BEB O&M	\$0.3	\$5.3	\$6.5
Transfer to Reserve, Specialized BEB	\$2.3	\$12.3	\$13.2
<b>Total</b>	<b>\$5.7</b>	<b>\$18.0</b>	<b>\$19.6</b>



**Table 62** below shows the annual fuel cost estimates for the specialized transit fleet for selected years.

**Table 62. BEB Scenario Periodic Specialized Fleet Fuel Costs, 2023\$, Millions**

	2023 - 2030	2031 - 2040	2041 - 2050
<b>Annual Electricity Costs</b>	\$0.1	\$1.0	\$1.2
<b>Annual Diesel Fuel Costs</b>	\$1.8	\$0.2	-
<b>Annual Carbon Levy Costs</b>	\$0.5	\$0.1	-
<b>Total Fuel Costs</b>	<b>\$2.3</b>	<b>\$1.3</b>	<b>\$1.2</b>

## BEB TRANSITION SUMMARY

Under the BEB Transition Scenario, the total cost of implementation was estimated to be \$729.8 million in 2023 dollars. The total capital costs are \$273.6 million. Total lifecycle O&M costs of \$456.3 million include operations, maintenance, lifecycle replacement costs, and propulsion costs. O&M costs make up the largest fraction of the total with approximately \$435.6 million in costs in 2023 dollars.

**Table 63. BEB Scenario Summary, 2023\$, Millions, 2023-2050**

2023\$	BEB Transition Scenario
<b>Buses</b>	\$204.5
<b>Midlife Rehabilitation</b>	\$2.8
<b>Specialized Transit</b>	\$34.4
<b>Related Infrastructure</b>	\$31.8
<b>Life Cycle Capital Costs, Total</b>	<b>\$273.6</b>
<b>Operations &amp; Maintenance</b>	\$393.0
<b>Propulsion</b>	\$41.1
<b>Related Infrastructure O&amp;M</b>	\$1.5
<b>Life Cycle O&amp;M, Fixed Route</b>	<b>\$435.6</b>
<b>Operations &amp; Maintenance</b>	\$15.5
<b>Propulsion</b>	\$5.1
<b>Life Cycle O&amp;M, Specialized Transit</b>	<b>\$20.7</b>
<b>Total Fleet Lifecycle Costs</b>	<b>\$729.8</b>

## LIFECYCLE COST COMPARISON

This section provides a comparison of the capital, O&M, and fuel/electricity cost estimates among the three scenarios over the entire 2023-2050 period. All values are presented in 2023\$ terms, unless otherwise noted.

## CAPITAL COST COMPARISON

**Table 64** provides a comparison of total capital costs among the two scenarios. As shown in the table, capital costs in the BEB Scenario are \$64.0 million more expensive due primarily to the difference in vehicle costs, as well as the additional equipment and infrastructure investments that would be required for BEB implementation.



**Table 64. Capital Cost Comparison, 2023\$ Millions, 2023-2050**

	Baseline	BEB	Variance
<b>Diesel – Replacement</b>	\$42.1	\$6.4	-\$35.7
Diesel Replacement Quantity	45	7	
<b>Diesel – Growth</b>	\$65.9	\$11.0	-\$54.9
Diesel Growth Quantity	72	12	
<b>BEB – Replacement</b>	-	\$72.6	\$72.6
BEB Replacement Quantity	-	38	
<b>BEB – Growth</b>	-	\$114.6	\$114.6
BEB Growth Quantity	-	60	
<b>8m Specialized ICE – Replacement</b>	\$6.2	\$0.8	-\$5.4
8m ICE Replacement Quantity	24	3	
<b>8m Specialized BEB – Replacement</b>	-	\$9.7	\$9.7
8m BEB Replacement Quantity	-	21	
<b>6m Specialized ICE – Replacement</b>	\$11.6	\$0.7	-\$10.9
6m ICE Replacement Quantity	53	3	
<b>6m Specialized BEB – Replacement</b>	-	\$19.7	\$19.7
6m BEB Replacement Quantity	-	50	
<b>6m Specialized ICE – Growth</b>	\$2.4	\$0.9	-\$1.5
6m ICE Growth Quantity	11	4	
<b>6m Specialized BEB – Growth</b>	-	\$2.8	\$2.8
6m BEB Replacement Quantity	-	7	
<b>Total Fleet Purchases</b>	<b>\$128.2</b>	<b>\$239.0</b>	<b>\$110.8</b>
<b>Diesel Midlife Rehabilitation</b>	\$81.4	\$2.3	-\$79.2
<b>BEB Midlife Rehabilitation</b>	-	\$0.5	\$0.5
<b>Additional Infrastructure</b>	-	\$31.8	\$31.8
<b>Total Fleet Lifecycle Capital Costs</b>	<b>\$209.6</b>	<b>\$273.6</b>	<b>\$64.0</b>

## O&M COST COMPARISON

**Table 65** provides a comparison of total operating and maintenance cost estimates over the 2023 to 2050 period based on the assumptions described in the prior sections. As mentioned earlier the primary unknown for O&M costs is vehicle maintenance costs for BEBs and associated infrastructure. The technology is still relatively new and long-term detailed analysis of vehicle maintenance costs is not available.



**Table 65. O&M Cost Comparison, 2023\$ Millions, 2023-2050**

	Baseline	BEB	Variance
<b>Diesel O&amp;M</b>	\$414.2	\$121.8	-\$292.4
<b>BEB O&amp;M</b>	-	\$286.7	\$286.7
<b>Diesel Bus – Transfer to Reserve</b>	\$89.0	-	-\$89.0
<b>BEB – Transfer to Reserve</b>	-	\$153.7	\$153.7
<b>8m Specialized Gas Transfer to Reserve</b>	\$5.1	-	-\$5.1
<b>8m Specialized BEB Transfer to Reserve</b>	-	\$8.8	\$8.8
<b>6m Specialized Gas Transfer to Reserve</b>	\$11.3	-	-\$11.3
<b>6m Specialized BEB Transfer to Reserve</b>	-	\$20.3	\$20.3
<b>Electrical Infrastructure Transfer to Reserve</b>	-	\$8.3	\$8.3
<b>Related Infrastructure O&amp;M Costs</b>	-	\$1.5	\$1.5
<b>Total Fleet Lifecycle O&amp;M Costs</b>	<b>\$519.7</b>	<b>\$601.2</b>	<b>\$81.4</b>

Finally, **Table 66** provides a comparison of total costs for diesel fuel and electricity over the 2023 to 2050 period. Based on the assumptions in this analysis, the BEB Scenario would have lower fuel and electricity costs in 2023-dollar terms.

**Table 66. Fuel and Electricity Cost Comparison, 2023\$ Millions, 2023-2050**

	Baseline	BEB	Variance
<b>Diesel Costs</b>	\$49.5	\$16.6	-\$32.9
<b>Electricity Costs</b>	-	\$23.8	\$23.8
<b>Carbon Levy Costs</b>	\$19.4	\$5.7	-\$13.6
<b>Total Fleet Lifecycle Propulsion Costs</b>	<b>\$68.9</b>	<b>\$46.2</b>	<b>-\$22.7</b>

## NET PRESENT VALUE (NPV) ANALYSIS

A net present value (NPV) analysis was conducted to compare the BEB Scenario to the Baseline Scenario. Costs over the 2023 to 2050 period are presented in 2023 dollars. The analysis evaluated the direct cost impacts to Milton Transit to understand the additional costs of implementing a BEB transition plan relative to operating business-as-usual.

This analysis assumed growth in service levels according to the proposed fleet expansion schedule provided by Milton Transit. The analysis only looks at direct cost impacts to Milton and does not attempt to monetize public benefits to society.

Additionally, the analysis assumed that capital costs will not be offset by grant or incentive funding. Including additional funding sources, such as ICIP or ZETF, may affect the results of the analysis. However, since these funds have not been applied for or secured by Milton, they are not included in this analysis.

The transition to BEBs is anticipated to cost \$37.1 million more than maintaining a fully diesel fleet for the BEB scenario. The result shows that the higher capital costs of BEB buses is not offset by O&M and



propulsion cost savings relative to the Baseline Scenario. Please note that the transfer to reserve costs is not included in the totals for either scenario, as this would substantially overstate the projected costs.

**Table 67. Overall Lifecycle Cost Comparison, Millions of 2023\$, 2023-2050**

2023\$	Baseline Scenario	BEB Transition Scenario	Variance
<b>Buses</b>	\$108.0	\$204.5	\$96.6
<b>Midlife Rehabilitation</b>	\$81.4	\$2.8	-\$78.7
<b>Specialized Transit</b>	\$20.2	\$34.4	\$14.2
<b>Related Infrastructure</b>	-	\$31.8	\$31.8
<b>Life Cycle Capital Costs, Total</b>	<b>\$209.6</b>	<b>\$273.6</b>	<b>\$64.0</b>
<b>Operations &amp; Maintenance</b>	\$398.4	\$393.0	-\$5.5
<b>Propulsion</b>	\$55.7	\$41.1	-\$14.6
<b>Related Infrastructure O&amp;M</b>	-	\$1.5	\$1.5
<b>Life Cycle O&amp;M, Fixed Route</b>	<b>\$454.1</b>	<b>\$435.6</b>	<b>-\$18.5</b>
<b>Operations &amp; Maintenance</b>	\$15.8	\$15.5	-\$0.2
<b>Propulsion</b>	\$13.2	\$5.1	-\$8.1
<b>Life Cycle O&amp;M, Specialized Transit</b>	<b>\$29.0</b>	<b>\$20.7</b>	<b>-\$8.3</b>
<b>Total Fleet Lifecycle Costs</b>	<b>\$692.7</b>	<b>\$729.8</b>	<b>\$37.1</b>

## INFRASTRUCTURE FINANCING OPTIONS

There are several external financing opportunities available to Milton to secure funding for its BEB fleet transition. The two primary external funding sources are the Investing in Canada Infrastructure Program (ICIP), and the Zero Emission Transit Fund (ZETF).

The ICIP is administered by Infrastructure Canada and has invested \$131 billion in over 85,000 projects. This program has already funded several other municipalities’ transit fleet buses, including conventional transit and other mobility services. The federal government will invest up to 40% for most municipal public transit costs, though this may increase to 50% for rehabilitation projects. Funding provided by Infrastructure Canada is divided among the provinces who distribute funding by municipality.

The ZETF is administered by the Canadian Infrastructure Bank, and targets projects that enable or implement transit fleet electrification. The ZETF offers flexible financing solutions, including grants and loans to applicants. ZETF funding decisions are determined by project viability, estimated operational savings, and estimated GHG emission reduction. Approximately \$2.75 billion in funding is earmarked for the ZETF program to numerous municipal transit agencies.

Funding from either program may be used to offset planning, capital, and operating costs associated with transitioning diesel fleets to BEBs or alternative fuel technologies. As this funding has not been secured by Milton, it is not included in this analysis.



## APPENDIX D: GHG EMISSIONS ANALYSIS

Greenhouse gas (GHG) emission reductions is an additional benefit of transitioning from diesel buses to BEBs. HDR performed supplementary calculations to quantify the impacts of BEB operations on GHG emissions relative to the Baseline Scenario.

### ASSUMPTIONS AND METHODOLOGY

The analysis quantified GHG impacts based on estimates of diesel fuel and electricity usage by conventional transit buses over the 2023-2050 period. The following assumptions were used to quantify emissions based on litres of fuel and kWh of electricity consumed.

The emission rate for diesel fuel is 2.681 kilograms (kgs) of carbon dioxide (CO<sub>2</sub>) per litre of fuel. The emission rate for gasoline fuel is 2.28 kgs of CO<sub>2</sub> per litre of fuel. This value was obtained from the Canadian National Inventory Report, 2023. The emission rate was multiplied by the annual litres of fuel consumed to calculate the annual kgs of CO<sub>2</sub> emitted. To quantify the impact of electricity usage on GHG emissions, the total kWh of electricity used per year was multiplied by the corresponding Electricity Emission Intensity factor for Ontario from 2023 to 2050. This factor represents the kg of CO<sub>2</sub> per kWh based on the average electricity grid mix for the province. The intensity factor declines over time due to anticipated introduction of new renewable power generation sources. The Electricity Emission Intensity Factor was obtained from the Average Grid Electricity Emission Intensities table in the ZETF GHG+ Guidance Modules, Annex C.

### GHG EMISSION REDUCTION IMPACTS

Based on the assumptions above, the GHG emissions from BEB operations are summarized in **Table 68** below. Over the study period, BEBs will reduce emissions by approximately 76,900 tonnes.

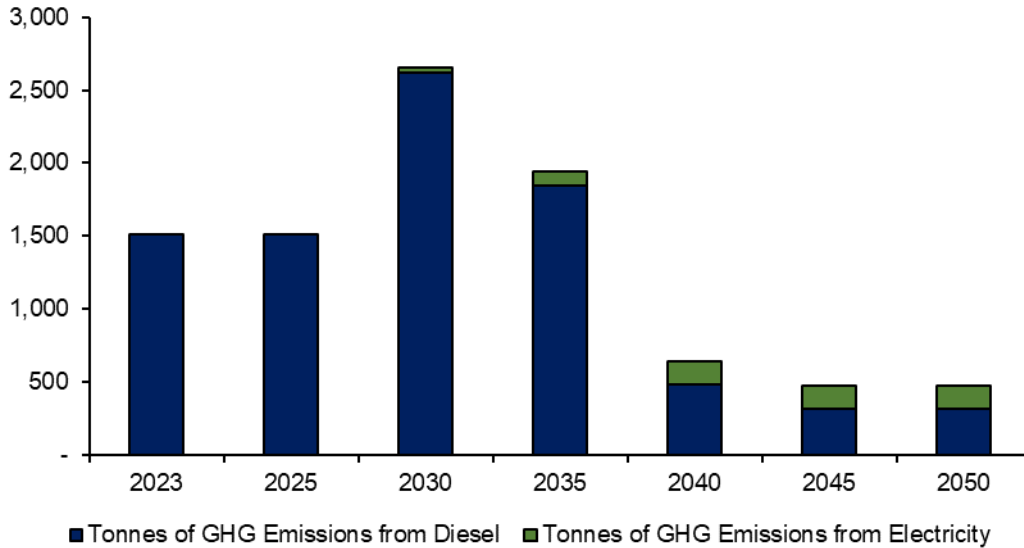
**Table 68. Total GHG Emissions (CO<sub>2</sub> in Tonnes), Baseline and BEB Scenarios**

	2025	2030	2040	Total
Diesel	2,168	4,134	5,156	120,466
BEB	-	-	-	-
<b>Total, Baseline Scenario</b>	<b>2,168</b>	<b>4,134</b>	<b>5,156</b>	<b>120,466</b>
Diesel	2,168	3,144	487	40,374
BEB	-	40	174	3,131
<b>Total, BEB Scenario</b>	<b>2,168</b>	<b>3,184</b>	<b>662</b>	<b>43,505</b>

This reduction is due to the dramatically lower operating emissions of BEBs relative to diesel buses. **Figure 28** below shows the annual GHG emissions from operations as the fleet mix changes in the BEB Scenario. There is a substantial decline from approximately 2,200 tonnes of GHGs per year to just below 700 tonnes per year in the BEB Scenario.

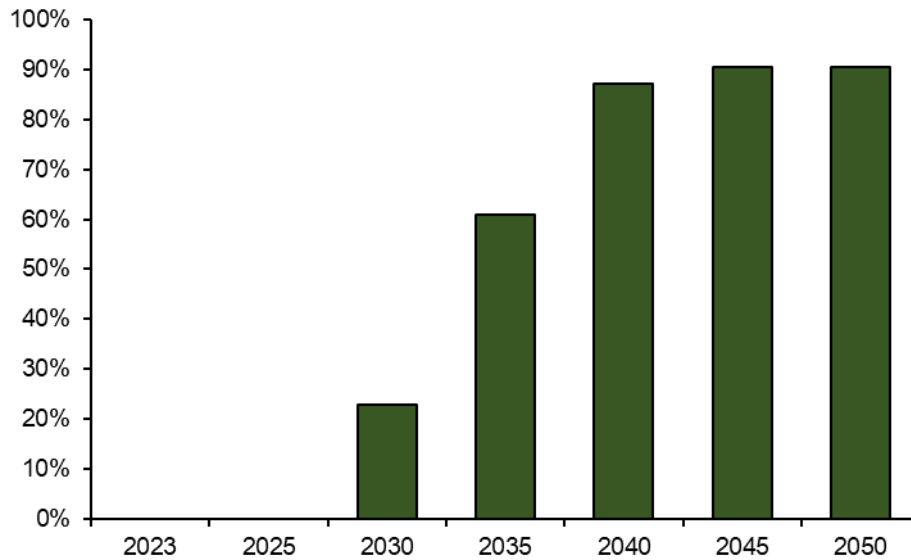






**Figure 28. Annual GHG Emissions, BEB Scenario, tonnes**

The cumulative percent reduction in GHG emissions is shown in **Figure 29** below. The annual reduced emissions grow substantially over time as the diesel fleet is converted to BEBs. By the end of the transition to BEBs, emissions are reduced by approximately 90%.



**Figure 29. Percentage GHG Reductions from Baseline in BEB Scenario**

